

STATE OF HAWAII  
DEPARTMENT OF TRANSPORTATION  
HIGHWAYS  
HONOLULU, HAWAII

SPECIAL PROVISIONS, SPECIFICATIONS, PROPOSAL

AND CONTRACT

FOR

FURNISHING AND DELIVERING TRAFFIC SIGNS

ISLANDS OF OAHU, HAWAII, MAUI AND KAUAI

PROJECT NO. HWY-C-09-23

2023

NOTICE TO BIDDERS  
(Chapter 103D, HRS)

SEALED BIDS for FURNISHING AND DELIVERING TRAFFIC SIGNS, ISLANDS OF OAHU, HAWAII, MAUI AND KAUAI, PROJECT NO. HWY-C-09-23, will begin as advertised on HiePRO. Bidders shall register and submit complete bids through HiePRO only. Refer to the following HiePRO link for important information on registering: <https://hiepro.ehawaii.gov/welcome.html>.

Deadline to submit bids is September 29, 2023, at 2:00 p.m., Hawaii Standard Time (HST). **Bidders shall submit and upload the complete proposal to HiePRO prior to the bid opening date and time. Proposals received after said due date and time shall not be considered. Any additional supporting documents explicitly designated as confidential and/or proprietary shall be uploaded as a separate file to HiePRO. Do not include confidential and/or proprietary documents with the proposal. The record of each bidder and respective bid shall be open to public inspection. FAILURE TO UPLOAD THE PROPOSAL TO HiePRO SHALL BE GROUND FOR REJECTION OF THE BID.**

The scope of work consists of furnishing and delivering traffic signs to various Highways District Offices on the islands of Oahu, Hawaii, Maui and Kauai, on an “as-needed” basis.

All Request for Information (RFI) questions and substitution requests shall be submitted via HiePRO **no later than fourteen (14) calendar days** before bid opening. RFI questions received after the stated deadline will not be addressed. Verbal RFIs will not receive a response. All responses to RFI questions shall be issued by formal addendum and posted in HiePRO.

Campaign contributions by State and County Contractors. Contractors are hereby

Matls. & Serv.

notified of the applicability of Section 11-355, HRS, which states that campaign contributions are prohibited from specified State or county government contractors during the term of the contract if the contractors are paid with funds appropriated by a legislative body. For more information, contact the Campaign Spending Commission at (808) 586-0285.

Protests. Any protest of this solicitation shall be submitted in writing to the Director of Transportation, in accordance with §103D-701, HRS and §3-126, HAR.

The Equal Employment Opportunity Regulations of the Secretary of Labor implementing Executive Order 11246, as amended, shall be complied with on this project.

The U.S. Department of Transportation Regulation entitled “Nondiscrimination in Federally-Assisted Programs of the U.S. Department of Transportation,” Title 49, Code of Federal Regulations (CFR), Part 21 is applicable to this project. Bidders are hereby notified that the Department of Transportation will affirmatively ensure that the contract entered into pursuant to this advertisement will be awarded to the lowest responsible bidder without discrimination on the grounds of race, color, national origin or sex (as directed by 23 CFR Part 200).

For additional information, contact Jake Dickman, Project Manager, by phone at (808) 587-2189, or by email at jake.j.dickman@hawaii.gov. The State reserves the right to reject any or all proposals and to waive any defects in said proposals for the best interest of the public.



---

ROBIN K. SHISHIDO  
Deputy Director of Transportation  
for Highways

TABLE OF CONTENTS

	<u>Page No.</u>
Notice to Bidders	
Special Provisions.....	SP-1 – SP-6
Specifications (Materials)	
Section 1    Definition and Terms .....	1-1 – 1-4
Section 2    Proposal Requirements and Conditions .....	2-1 – 2-3
Section 3    Award and Execution of Contract.....	3-1 – 3-3
Section 4    Scope of Work .....	4-1 – 4-3
Section 5    Control of Work.....	5-1 – 5-2
Section 6    Control of Materials.....	6-1 – 6-3
Section 7    Legal Relations and Responsibility .....	7-1 – 7-4
Section 8    Prosecution and Progress .....	8-1 – 8-7
Section 9    Payment.....	9-1 – 9-2
Section 10   Furnishing and Delivering Traffic Signs .....	10-1 – 10-9
Appendices	
Appendix A – Standard Plan.....	TE-04 - TE-08, TE-11, TE-12
Appendix B – Non-standard sign, “Unlawful to Litter \$1000 Fine” .....	B-1
Appendix C – Non-standard sign, “No Camping” .....	C-1
Appendix D – Non-standard sign, “Bicycle (symbol) Lane Ahead” .....	D-1
Appendix D1 – Non-standard sign, “No Right Turn On Red Except From Right Lane After Stop” .....	D1-1
Appendix E – Non-standard sign, “Trucks Test Brakes” .....	E-1

	<u>Page No.</u>
Appendix E1 – Non-standard sign, “On Left Arrow Only U Turn OK” .....	E1-1
Appendix E2 – Non-standard sign, “On Left Arrow Only No U Turn” .....	E2-1
Appendix E3 – Non-standard sign, “On Left Arrow Only” .....	E3-1
Appendix E4 – Non-standard sign, “On Left Arrow Only U Turn OK.....	E4-1
Appendix F – Non-standard sign, “On Left Arrow Only No U Turn .....	F-1
Appendix G – Non-standard sign, “No Dumping” .....	G-1
Appendix G1 – Non-standard sign, “No Jumping From Bridge” .....	G1-1
Appendix G2 – Non-standard sign, “No Vending” .....	G2-1
Appendix G3 – Non-standard sign, “Keep Out Government Property Trespassers Will Be Prosecuted State Department of Transportation Highways Division HRS 264-12, HRS 264-6, HRS 708-815” .....	G3-1
Appendix H – Non-standard sign, “Truck Crossing When Flashing” .....	H-1
Appendix I – Non-standard sign, “Rumble Strips Ahead” .....	I-1
Appendix I1 – Non-standard sign, Clearance Marker .....	I1-1
Appendix J – Non-standard sign, “Adopt a Highway Litter Control Next 2 Miles” .....	J-1
Appendix K – Modified MUTCD Sign, “Ahupua‘a” .....	K-1
Appendix L – Modified MUTCD Sign, “Watch for Pedestrians” .....	L-1
Appendix M – Modified MUTCD Sign, “School Xing” .....	M-1
Appendix N – Modified MUTCD Sign, “Stop Ahead” .....	N-1

	<u>Page No.</u>
Appendix O – Amended Section 750.01(B) Traffic Control Sign and Marker Materials .....	O-1 – O-2
Appendix P – Sample – Monthly Invoice.....	P-1
Appendix Q – Sample – Satisfactory Evidence by Affidavit for Final Payment.....	Q-1
Proposal.....	PF-1 – PF-5
Proposal Schedule.....	PF-6 – PF-47
Forms	
Sample Contract.....	KF-1 – KF-2

STATE OF HAWAII  
DEPARTMENT OF TRANSPORTATION  
HIGHWAYS  
HONOLULU, HAWAII

SPECIAL PROVISIONS

## SPECIAL PROVISIONS

These specifications contained herein are amended as follows:

A. SECTION 1 – DEFINITION AND TERMS shall be amended as follows:

1. 1.33 SUBCONTRACTOR shall be amended in its entirety to read as follows:

“1.33 SUBCONTRACTOR – An individual, partnership, firm, corporation, or joint venture, or other legal entity, as licensed or required to be licensed under Chapter 444, Hawaii Revised Statutes, as amended, which enters into an agreement with the Contractor to perform a portion of the work.”

2. 1.38 WORKING DAY shall be amended in its entirety to read as follows:

“1.38 WORKING DAY – Every day, except Saturdays, Sundays, and State holidays as applicable and as observed.

Normal State holidays are as follows:

New Year’s Day (The first day of January)  
Dr. Martin Luther King, Jr. Day (The third Monday in January)  
President’s Day (The third Monday in February)  
Prince Jonah Kuhio Kalaniana’ole Day (The twenty-sixth day in March)  
Good Friday (The Friday preceding Easter Sunday)  
Memorial Day (The last Monday in May)  
King Kamehameha I Day (The eleventh day in June)  
Independence Day (The fourth day in July)  
Statehood Day (The third Friday in August)  
Labor Day (The first Monday in September)  
General Election Day (The first Tuesday in November following the first Monday of even numbered years)  
Veteran’s Day (The eleventh day in November)  
Thanksgiving (The fourth Thursday in November)  
Christmas (The twenty-fifth day in December)

State Holiday schedules can be obtained online at:

<http://dhrd.hawaii.gov/state-observed-holidays/>”

3. Add the following new subsection:

“1.39 HAWAII ePROCUREMENT SYSTEM (HIePRO) - The State of Hawaii eProcurement System for issuing solicitations, receiving proposals and responses, and issuing notices of award.



1.40 ENGINEER – The respective District Engineer, acting directly or through their duly authorized representatives, who are responsible for District engineering supervision of construction and other highway matters.

1.41 STANDARD SPECIFICATIONS – The Hawaii Standard Specifications for Road and Bridge Construction, 2005, Highways Division, Department of Transportation, including any amendments. Log on to:

<http://hidot.hawaii.gov/highways/s2005-standard-specifications/>

to review the 2005 Standard Specifications and their applicable amendments/Special Provisions.

The Contractor shall utilize the latest revision.

1.42 STANDARD PLANS – The Standard Plans, 2008, issued by the State of Hawaii, Department of Transportation, Highways Division, Design Branch, as amended, revised or updated.

The Standard Plans are available from the Department of Transportation, Highways Division. For information, log on to:

<https://hidot.hawaii.gov/highways/s2005-standard-specifications/>

The Contractor shall utilize the latest revision.

1.43 MUTCD – The Manual on Uniform Traffic Control Devices, 2009, Federal Highway Administration, U.S. Department of Transportation, including any amendments or revisions. To review the MUTCD, log on to:

<http://mutcd.fhwa.dot.gov/>

The Contractor shall utilize the latest revision.

1.44 OSHA – The U.S. Department of Labor (DOL), Occupational Safety and Health Administration (OSHA). To review the OSHA, log on to:

<https://www.osha.gov/>

B. SECTION 2 – PROPOSAL REQUIREMENTS AND CONDITIONS shall be amended as follows:

1. 2.3 DELIVERY OF PROPOSALS is amended by replacing the entire subsection with:

**“2.3 DELIVERY OF PROPOSALS – Bidders shall submit and upload the complete proposal to HIePRO prior to the bid opening date and time. Proposals received after said due date and time shall not be considered. Original (wet ink, hard copy) proposal documents are not required to be submitted. Contract award shall be based on evaluation of proposals submitted and uploaded to HIePRO. Any additional support documents explicitly designated as confidential and/or proprietary shall be uploaded as a separate file to HIePRO. Do not include confidential and/or proprietary documents with the proposal.** The record of each bidder and respective bid shall be open to public inspection.

**FAILURE TO UPLOAD THE COMPLETE PROPOSAL TO HIePRO SHALL BE GROUNDS FOR REJECTION OF THE BID.**

If there is a conflict between the specification document and the HIePRO solicitation, the specifications shall govern and control, unless otherwise specified.”

2. 2.4 WITHDRAWAL OF PROPOSALS shall be amended by replacing the entire subsection with:

“2.4 WITHDRAWAL OF PROPOSALS – A bidder may withdraw or revise a proposal after the bidder submits the proposal in HIePRO. Withdrawal or revision of proposal must be completed before the time set for receiving of bids.”

3. 2.5 PUBLIC OPENING OF PROPOSALS is not applicable.

4. 2.8 OUT OF STATE BIDDERS shall be amended by adding the following to the end of the subsection:

“Successful out-of-state bidders shall, after ten (10) days from the Notice to Proceed, provide a name and phone number of the Contractor’s Technical Representative who will be responsible in assisting the recipient districts throughout the duration of the contract. Corporations must be registered to do business in the State of Hawaii. For information on business registration, please call Department of Commerce and Consumer Affairs at (808) 586-2545 or log on to: <http://www.hawaii.gov/dcca/areas/breg>.

C. SECTION 3 – AWARD AND EXECUTION OF CONTRACT shall be amended as follows:

1. 3.1 AWARD OF CONTRACT shall be amended by adding the following to the end of the subsection:

“The State reserves the right to reject any and all proposal and to waive any defects as may be deemed to be in the best interest of the public. Any bid lacking a unit price or amount shall disqualify the bidder.”

D. SECTION 4 – SCOPE OF WORK shall be amended as follows:

1. 4.6 VARIATION IN QUANTITY shall be replaced in its entirety to read as follows:

“4.6 CONTRACT TO BE INDEFINITE QUANTITY – The requirement for materials to be furnished by the Contractor will be on an “as-needed” basis as called for in these Specifications at the applicable unit price bid during the term of this contract and in such numbers as may be required by the State. The quantities specified in the contract is an estimate and does not signify a minimum or maximum amount. The unit bid price indicated by the Contractor shall be applicable and binding under the terms of this contract. Payment for services will be made by Purchase Order.”

E. SECTION 6 – CONTROL OF MATERIALS AND EQUIPMENT shall be amended as follows:

6.2 TRADE NAMES AND ALTERNATES is amended as follows:

1. The first paragraph of A. QUALIFICATION BEFORE BID OPENING shall be replaced with the following:

“A. QUALIFICATION BEFORE BID OPENING - When the specifications and/or plans specify one or more manufacturer's brand names of materials or equipment to indicate a quality, style, appearance, or performance, the bidder will be assumed to have based its bid on one of the specified named products, except where such proprietary product are specified, alternate brands may be qualified if found equal or better by the Department. The bidder shall submit a request to the Department for review and approval at the earliest date possible. Requests shall be submitted via email to the Contact person listed in HiePRO for the solicitation and also posted as a question in HiePRO under the question/answer tab referencing the email with the request. The request must be posted in HiePRO no later than fourteen (14) calendar days before the bid opening date.”

2. The first sentence of the second paragraph of A. QUALIFICATION BEFORE BID OPENING shall be replaced with the following:

“It shall be the responsibility of the bidder to submit sufficient evidence based upon which a determination can be made by the Department that the alternate brand is a qualified equivalent”

- F. SECTION 8 – PROSECUTION AND PROGRESS shall be amended as follows:

1. 8.1 PROGRESS OF WORK shall be amended by adding the following paragraph to the end of the subsection:

“The Contractor shall diligently prosecute the work to completion within the time limit specified in the proposal. The Notice to Proceed will indicate the date the Contractor is expected to begin the work and from which date contract time will be charged. The Contractor shall give his personal attention to the fulfillment of the contract and shall keep the work under his control.

If the materials fail to meet specification requirements, the Contractor will be notified of such and the material will be rejected. The Contractor shall replace the rejected material with those that meet the specification requirements, and liquidated damages in accordance with the 8.2 Liquidated Damages of the Special Provisions, will be assessed against him for late delivery any time after the required completion date. Time taken to perform the material sampling and testing, however, will not be charged against the Contractor.”

2. 8.2 LIQUIDATED DAMAGES shall be amended by as follows:

- a. Add the following to the end of the subsection:

“1/4 of 1% of the total contract price of each item for each calendar day for failure to deliver the items within the delivery period. The assessed amount, however, will be no less than TEN DOLLARS (\$10.00) for each bid item for each and every calendar day.”

- b. The following shall replace the first sentence of the second paragraph:

“Delivery extension shall be considered only with written notice **prior to delivery deadline**. Written notice requesting extension will not be considered without a copy of the factory order, factory confirmation of order and without documents substantiating that the cause(s) for delay is, in fact, beyond the control of the Contractor. The State shall be the sole judge of whether such delay is truly beyond the control of the Contractor and whether an extension will be granted.”

G. SECTION 9 – PAYMENT shall be amended as follows:

1. 9.2 PROGRESS PAYMENTS shall be amended by adding the following to the end of the subsection:

“D. Deductions, as applicable, shall be included in the invoices as subtotal(s) and labeled as either (1) and/or (2) below:

- (1) Retainage as specified in Section 9.2 Progress Payments, of the Specifications.
- (2) Liquidated Damages, as specified in Section 8.2 of the Special Provisions.

After the delivery of materials, the Contractor shall forward the required invoice as specified in Section 9.2 Progress Payments, of the Specifications, to the recipient district as applicable and as indicated below for approval of payments.

District Engineer – Oahu District Highways Division – State DOT Kakoi Baseyard 727 Kakoi Street Honolulu, Hawaii 96819	District Engineer – Hawaii District Highways Division – State DOT Hilo Baseyard 50 Makaala Street Hilo, Hawaii 96720
District Engineer – Maui District Highways Division – State DOT Kahului Baseyard 650 Palapala Drive Kahului, Hawaii 96732	District Engineer – Kauai District Highways Division – State DOT Lihue Baseyard 1720 Haleukana Street Lihue, Hawaii 96766

The Engineer shall issue a Purchase Order for payments to pay for all furnished, delivered, and accepted materials.

*Pursuant to the State of Hawaii Department of Transportation (DOT) Procurement Delegation signed by the DOT Director on October 8, 2012, Purchase Orders may not be issued or used unless there is a Purchase Requisition signed by an authorized person.”*

## SECTION 1 - DEFINITION AND TERMS

Whenever the following pronouns are used in these specifications, or in any documents or instruments where these specifications govern, the intent and meaning shall be interpreted as follows:

1.1 ADDENDA - A written document which may be issued by the Director during the bidding period involving changes to the specifications and plans, if any, which shall be considered and made a part of the contract.

1.2 AIRPORTS DIVISION - Airports Division, Department of Transportation, State of Hawaii.

1.3 AWARD - The written acceptance of a proposal by the State.

1.4 BIDDER - Any individual, partnership, corporation or other legal entity, or combination thereof, submitting a proposal for the work contemplated, acting either directly or through a duly authorized representative.

1.5 CALENDAR DAY - Every day shown on the calendar. If no designation of calendar or working day is made, "day" shall mean calendar day.

1.6 CHANGE ORDER - A written order issued by the Director to the Contractor requiring the contract work to be performed in accordance with a change or changes that may involve an adjustment in contract time and price or requiring performance of any unforeseen work essential to complete the contract.

1.7 CONTRACT - The written agreement between the State and the Contractor setting forth the obligations of the parties thereunder, including, but not limited to, the performance of the work, the furnishing of labor and materials, and the basis of payment.

The contract includes the (1) notice to bidders, (2) proposal, (3) contract form and contract bond, (4) specifications, (5) special provisions and plans, if any, (6) addenda, (7) notice to proceed, and (8) change orders and agreements that are required to complete the work, all of which constitute one instrument.

1.8 CONTRACT BOND - The approved form of security, executed by the Contractor and its Surety or Sureties, guaranteeing the completion of the work in accordance with the terms of the contract, and guaranteeing full payment of all claims for labor, materials, and supplies used or incorporated in the work.

1.9 CONTRACT TIME - The number of working days or calendar days allowed for completion of the contract, including authorized time extensions.

If a calendar date is specified as the date of completion in lieu of the number of working days or calendar days, the contract shall be completed by that date.

In case the contract is for a specified period of time, the contract time shall be for said specified period of time.

1.10 CONTRACTOR - The individual, partnership, corporation or other legal entity, or combination thereof, contracting with the State for performance of the prescribed work.

1.11 DEPARTMENT - The State Department of Transportation.

1.12 DIRECTOR - The Director of Transportation, acting either directly or through the Director's duly authorized representative.

1.13 EQUAL OR APPROVED EQUAL - Whenever this term is used in the specifications and plans, if any, it means a brand or article pre-qualified in accordance with Section 6.2 Trade Names and Alternates and which may be used in place of the one specified.

1.14 H.A.R. or HAR - Hawaii Administrative Rules.

1.15 H.R.S. or HRS - Hawaii Revised Statutes.

1.16 HARBORS DIVISION - Harbors Division, Department of Transportation, State of Hawaii.

1.17 HIGHWAYS DIVISION - Highways Division, Department of Transportation, State of Hawaii.

1.18 HOLIDAYS - The days which are set apart and established as State holidays pursuant to Section 8-1, H.R.S.

1.19 INSPECTOR - The Director's authorized representative assigned to make detailed inspections of contract performance and materials supplied.

1.20 NOTICE TO BIDDERS - The public announcement, as required by law, inviting proposals for the work to be performed or materials to be furnished.

1.21 NOTICE OF FINAL ACCEPTANCE - Written notice from the Director to the Contractor that the entire contract has been completed in all respects in accordance with the specifications and plans, if any, and any changes thereof previously approved by the Director.

1.22 NOTICE TO PROCEED - Written notice from the Director to the Contractor advising the Contractor of the date on which he is to begin the prosecution of the work.

1.23 PLANS - The contract drawings approved by the Director which show the location, character, dimensions and details of the work to be done and shall be a part of the contract.

1.24 PROCUREMENT OFFICER - The Director's duly authorized representative including project managers, project engineers and contract administrators assigned to prepare, evaluate and administer contracts for the purchasing of goods and services.

1.25 PROPOSAL (OR BID) - The offer of a bidder, on the prescribed form, to perform the work and to furnish the labor and materials at the prices quoted.

1.26 PROPOSAL FORM - The approved format prepared by the Department or a facsimile thereof on which bids for the work must be prepared and submitted. (Reasonable facsimile acceptable for bidding.)

1.27 PROPOSAL GUARANTY - The security furnished with a proposal to guarantee that the bidder will enter into the contract and furnish all other requirements if the bidder's proposal is accepted.

1.28 QUALIFICATION QUESTIONNAIRE - The specified forms on which the bidder shall furnish required information as to the bidder's ability to perform and finance the work.

1.29 S.L.H. or SLH - Session Laws of Hawaii.

1.30 SPECIAL PROVISIONS - Revisions to the specifications. The specific clauses setting forth conditions or requirements peculiar to the project under consideration which are not thoroughly or satisfactorily stipulated in these specifications.

1.31 SPECIFICATIONS - The directions, provisions, and requirements pertaining to the method and manner of performing the work and to the quantities and qualities of materials to be furnished under the contract.

1.32 STATE - The State of Hawaii.



1.33 SUBCONTRACTOR - An individual, partnership, corporation, other legal entity, or any combination thereof, that enters into an agreement with the Contractor to perform a portion of the work for the Contractor.

1.34 SUPERINTENDENT - The Contractor's representative who is responsible for and in charge of the work.

1.35 SURETY - The corporation, partnership or individual, other than the Contractor, executing a bond furnished by the Contractor and guaranteeing performance by the Contractor.

1.36 TITLES (OR HEADINGS) - The titles or headings of the Sections herein are intended for convenience of reference and shall not be considered as having any bearing on their interpretation. Unless otherwise indicated, whenever the word "Section" is used, reference is being made to a Section in these specifications.

1.37 WORK - The furnishing of all labor, materials, equipment, and other incidentals necessary or convenient for the successful completion of the project and the execution of all the duties and obligations imposed by the contract.

1.38 WORKING DAY - Any day, except Saturdays, Sundays and State holidays.

## SECTION 2 - PROPOSAL REQUIREMENTS AND CONDITIONS

2.1 PROPOSAL FORMS - All proposals shall be made on forms furnished by the Department. All proposals shall give the prices proposed in the spaces provided and shall be signed by the bidder, who shall fill out all blanks in the proposal form as therein required.

2.2 REJECTION OF PROPOSALS CONTAINING ALTERATIONS, ERASURES, OR IRREGULARITIES - Proposals may be rejected if they show any alterations of form, additions not called for, conditional bids, incomplete bids, erasures, or irregularities of any kind.

When proposals are signed by any agent, other than the officer or officers of a corporation authorized to sign contract on its behalf or a member of copartnership, a Power of Attorney must be on file with the Department prior to opening bids or shall be submitted with the proposal; otherwise, the proposal may be rejected as irregular and unauthorized.

Members of a joint venture may be requested to supply the Department with a copy of their joint venture agreement or each member of the joint venture may be required to sign the proposal.

2.3 DELIVERY OF PROPOSALS - Each proposal shall be placed, together with the proposal guaranty, when required, in an envelope and sealed and so marked as to indicate the identity of the project, the name and address of the bidder, and other required information and then delivered as indicated in the Notice to Bidders. Proposals will be received up to the time fixed in the Notice to Bidders for the opening of bids.

2.4 WITHDRAWAL OF PROPOSALS - Any proposal may be withdrawn at any time prior to the time fixed in the Notice to Bidders for the opening of proposals upon the filing of a written request therefor with the Department, executed by the bidder or his duly authorized representative. The withdrawal of a proposal shall not preclude a bidder from submitting a new proposal.

2.5 PUBLIC OPENING OF PROPOSALS - Proposals will be opened and read publicly at the time and place indicated in the Notice to Bidders. Bidders or their authorized agents are invited to be present.

2.6 DISQUALIFICATION OF BIDDERS - Any of the following reasons may be considered as being sufficient grounds for the disqualification of a bidder and the rejection of his proposal or proposals.

A. More than one proposal for the same work from an individual, firm, or corporation under the same or different name.

B. Evidence of collusion among bidders. Participants in such collusion will receive no recognition as bidders for any future work of the Department until such participant shall have been reinstated as a qualified bidder.

C. Evidence of assistance from a person who has been an employee of the agency within the preceding two years and who participated while in State office or employment in the matter with which the contract is directly concerned, pursuant to Section 84-15, HRS.

D. Lack of proposal guaranty.

E. Unsigned proposal or proposal not signed in ink by person or persons legally authorized to submit a proposal on behalf of the bidder.

2.7 MATERIAL GUARANTY - The bidder may be required to furnish a complete statement of the origin, composition and manufacture of any or all materials to be used in the prosecution of the work, together with samples. Such samples may be subjected to tests to determine their quality and fitness for the work.

2.8 OUT-OF-STATE BIDDERS - Pursuant to Section 103D-1008, Hawaii Revised Statutes, on out-of-state purchases where the bidder or vendor is an out-of-state vendor, not doing business in the State, the bid price of such out-of-state vendor, for the purpose of determining the lowest price bid, shall be increased by the applicable retail rate of general excise tax and the applicable use tax. The lowest responsible bidder, taking into consideration the above increases, shall be awarded the contract, but the contract amount of any contract awarded shall be the amount of the bid offered and shall not include the amount of said increases.

Such increases will not be applied in case an out-of-state vendor specifies in its bid that its bid price includes said general excise tax; the bidder will be required to pay said general excise tax and use tax in case the bidder is awarded the contract.

2.9 TAX REQUIREMENTS - Work to be done under this contract is a taxable transaction and the bidder receiving the award for this work will be required to pay the State of Hawaii General Excise Tax (GET) and the State of Hawaii use Tax.

Additional information regarding the tax rates may be obtained from the Department of Taxation (DOTAX) website at <http://tax.hawaii.gov/geninfo/countysurcharge/>

If awardee is an out-of-state bidder not holding a Hawaii GET License, the awardee will have to obtain a Hawaii GET License and pay all taxes due to obtain a tax clearance required before final contract payment is made by the State.

To obtain the tax clearance applications, see subsection 3.1.A. Tax Clearance of these Specifications.

Vendors may apply for either a regular or a one-time GET License. Information on applying for a GET License may be found at <http://tax.hawaii.gov/geninfo/get/>

SECTION 3 - AWARD AND EXECUTION OF CONTRACT

3.1 AWARD OF CONTRACT - The State reserves the right to reject any and all proposals and to waive any defects as may be deemed to be in the best interest of the public.

The award of contract, if it be awarded, will be made within sixty (60) calendar days after the opening of bids to the lowest responsive and responsible bidder whose proposal complies with all the prescribed requirements. The successful bidder will be notified, by letter mailed to the address shown on its proposal, that its proposal has been accepted and it has been awarded the contract.

**Requirement for award.** To be eligible for award, the apparent low Bidder will be contacted to submit copies of the documents listed below to demonstrate compliance with Section 103D-310(c), HRS. The documents should be submitted to the Department as soon as possible. If a valid certificate/clearance is not submitted on a timely basis for award of a contract, a Bidder otherwise responsive and responsible may not receive the award.

**A. Tax Clearance.**

Pursuant to §103D-310(c), 103-53 and 103D-328, HRS, the successful bidder shall be required to submit a certified copy of its tax clearance issued by the Hawaii State Department of Taxation (DOTAX) and the Internal Revenue Service (IRS) to demonstrate its compliance with Chapter 237, HRS. A tax clearance is valid for six (6) months from the most recent approval stamp date on the tax clearance and must be valid on the bid's first legal advertisement date or any date thereafter up to the bid opening date.

FORM A6, TAX CLEARANCE CERTIFICATE, is available at the following website:

<http://www.hawaii.gov/tax/>

To receive DOTAX Forms by fax or mail, phone (808)587-7572 or 1-800-222-7572.

The application for the Tax Clearance Certificate is the responsibility of the bidder, and must be submitted directly to the DOTAX or IRS. The approved certificate may then be submitted to the Department.

**B. DLIR Certificate of Compliance.**

Pursuant to §103D-310(c), HRS, the successful bidder shall be required to submit a copy (faxed copies are acceptable) of its approved Certificate of Compliance issued by the Hawaii State Department of Labor and Industrial Relations (DLIR) to demonstrate its compliance with unemployment insurance (Chapter 383, HRS), workers' compensation (Chapter 386, HRS), temporary disability insurance (Chapter 392, HRS), and prepaid health care (Chapter 393, HRS). The certificate is valid for six (6) months from the most recent approval stamp date on the certificate and must be valid on the bid's first legal advertisement date or any date thereafter up to the bid opening date. For certificates which receive a "pending" approval stamp, a DLIR approval stamp is required prior to the issuance of the Notice to Proceed.

FORM LIR#27, APPLICATION FOR CERTIFICATE OF COMPLIANCE WITH SECTION 3-122-112, HAR, is available at the following website:

[www.hawaii.gov/labor](http://www.hawaii.gov/labor)

More information is available by calling the DLIR Unemployment Insurance Division at (808) 586-8926.

Inquiries regarding the status of a LIR#27 Form may be made by calling the DLIR Disability Compensation Division at (808)586-9200.

The application for the Certificate of Compliance is the responsibility of the bidder, and must be submitted directly to the DLIR. The approved certificate may then be submitted to the Department.

**C. DCCA Certificate of Good Standing.**

Pursuant to §103D-310(c), HRS, the successful bidder shall be required to submit a copy (faxed copies are acceptable) of its approved Certificate of Good Standing issued by the Hawaii State Department of Commerce and Consumer Affairs (DCCA), Business Registration Division (BREG) to demonstrate that it is either:

- (1) incorporated or organized under the laws of the State; or
- (2) registered to do business in the State as a separate branch or division that is

capable of fully performing under the contract.

A Certificate of Good Standing is valid for six (6) months from the approval date on the certificate and must be valid on the bid's first legal advertisement date or any date thereafter up to the bid opening date. A Hawaii business that is a sole proprietorship, is not required to register with the BREG, and therefore not required to submit a Certificate of Good Standing. Bidders are advised that there are costs associated with registering and obtaining a Certificate of Good Standing from the DCCA.

To purchase a CERTIFICATE OF GOOD STANDING, go to On-Line Services at the following website:

[www.hawaii.gov/dcca/](http://www.hawaii.gov/dcca/)

The application for the Certificate of Good Standing is the responsibility of the bidder, and must be submitted directly to the DCCA. The approved certificate may then be submitted to the Department.

3.2 CANCELLATION OF AWARD - The State reserves the right to cancel the award of any contract any time before the execution of said contract by all parties without any liability to the successful bidder or any other bidder.

3.3 EXECUTION OF CONTRACT - The contract shall be executed by the successful bidder and returned, together with the contract bonds, when required, within ten (10) days after the award of the contract or within such further time as the Director may allow after the bidder has received the contract for execution.

Pursuant to Section 103D-309, H.R.S., the contract shall not bind the State in any way unless said contract has been fully and properly executed by all the parties thereto and the Comptroller has endorsed thereon a certificate that there is available an unexpended appropriation over and above all outstanding contracts, sufficient to cover the amount required by the contract.

3.4 FAILURE TO EXECUTE CONTRACT - Failure to execute the contract and file acceptable bonds, when required, within ten (10) days after the award of the contract, or within such further time as the Director may allow, shall be cause for the cancellation of the award and the forfeiture of the proposal guaranty. Award of the contract may then be made to the next lowest responsible bidder.

## SECTION 4 - SCOPE OF WORK

4.1 WORK TO BE DONE - The work to be done is described in the Section(s) following Section 9 of these specifications.

4.2 PERFORMANCE OF WORK - The Contractor shall employ, so far as possible, such methods and means in carrying out his work so as not to cause any interruption, disturbance, or interference with the public.

In case the Contractor is performing work in a building, the Contractor shall conduct the work in such a manner so as not to cause any interruption, disturbance, or interference with the business activities of the tenants in the building.

4.3 EXTRA WORK - New and unforeseen items of work will be classed as extra work when they cannot be covered by any of the various items for which there is a bid price.

### 4.4 CHANGES AND CLAIMS FOR ADJUSTMENT

A. Change order. By a written order, at any time, and without notice to any surety, the procurement officer may, subject to all appropriate adjustments, make changes within the general scope of this contract in any one or more of the following:

1. Drawings, designs, or specifications, if the goods to be furnished are to be specially manufactured for the State in accordance therewith;
2. Method of shipment or packing;
3. Place of delivery;
4. Changes in the work within the scope of the contract; or
5. Changes in the time of performance of the contract that do not alter the scope of work.

B. Adjustments of price or time for performance. If any change order increases or decreases the contractor's cost of, or the time required for, performance of any part of the work under this contract, whether or not changed by the order, an adjustment shall be made and the contract modified in writing accordingly. Any adjustment in contract price made pursuant to this clause shall be determined in accordance with the price adjustment clause of this contract. Failure of the parties to agree to an adjustment shall not excuse the contractor from proceeding with the contract as changed, provided that the procurement officer promptly and duly make the provisional adjustments in payment or time for performance as may be reasonable. By proceeding with the work, the contractor shall not be deemed to have



prejudiced any claim for additional compensation, or an extension of time for completion.

C. Time period for claim. Within thirty (30) days after receipt of a written change order under subsection (a) unless the period is extended by the procurement officer in writing, the contractor shall file notice of intent to assert a claim for an adjustment. Later notification shall not bar the contractor's claim unless the State or county is prejudiced by the delay in notification.

D. Claim barred after final payment. No claim by the contractor for an adjustment hereunder shall be allowed if notice is not given prior to final payment under this contract.

E. Other claims not barred. In the absence of a change order, nothing in this clause shall be deemed to restrict the contractor's right to pursue a claim as under the contract or for breach of contract.

#### 4.5 PRICE ADJUSTMENT

Any adjustment in contract price pursuant to a clause in this contract shall be made in one or more of the following ways:

A. By agreement on a fixed price adjustment before commencement of the pertinent performance or as soon thereafter as practicable;

B. By unit prices specified in the contract or subsequently agreed upon;

C. By the costs attributable to the event or situation covered by the clause, plus appropriate profit or fee, all as specified in the contract or subsequently agreed upon;

D. In such other manner as the parties may mutually agree; or

E. In the absence of agreement between the parties, by a unilateral determination by the procurement officer of the costs attributable to the event or situation covered by the clause, plus appropriate profit or fee, all as computed by the procurement officer in accordance with generally accepted accounting principles and applicable sections of chapters 3-123 and 3-126 of the Hawaii Administrative Rules.

#### 4.6 VARIATION IN QUANTITY

Upon agreement of the parties, the quantity of goods or services or both specified in this contract may be increased by a maximum of ten (10) percent provided (1) the unit prices will remain the same except for any price adjustments otherwise applicable and (2) the procurement officer makes a written determination that such an increase will either be more economical than awarding another contract or that it would not be practical to award another contract.

SECTION 5 - CONTROL OF WORK

5.1 AUTHORITY OF DIRECTOR - The Director shall decide all questions which may arise as to the quality or acceptability of materials furnished and work performed, the manner of performance and rate of progress of the work, and compensation for work performed, interpretation of the contract and fulfillment of the contract on the part of the Contractor. The Director shall have authority to enforce and make effective such decisions and orders which the Contractor fails to carry out properly and diligently. The decision of the Director shall be final.

5.2 COORDINATION OF PLANS, SPECIFICATIONS AND SPECIAL PROVISIONS - These specifications, plans, special provisions, and all supplementary documents are essential parts of the contract, and a requirement occurring in one is as binding as though occurring in all. They are intended to be complementary and to describe and provide for a complete work.

5.3 CLAIMS AND DISPUTES - The Contractor may give notice in writing to the procurement officer for claims that extra compensation, damages, or an extension of time for completion is due the Contractor for one or more of the following reasons:

- A. Requirements not clearly covered in the contract, or not ordered by the procurement officer as an extra work;
- B. Failure between the State and the Contractor to agree to an adjustment in price for a contract change order issued by the State; or
- C. An action or omission on the part of the procurement officer requiring performance changes within the scope of the contract.

The Contractor shall continue with performance of the contract in compliance with the directions or orders of the procurement officer, but by so doing, the Contractor shall not be deemed to have prejudiced any claim for additional compensation, damages, or an extension of time for completion; provided:

- A. The notice in writing be given:
  - 1. Before the commencement of the work involved, if at that time the Contractor knows of such requirements or the occurrence of such actions or omissions; or
  - 2. Within thirty (30) calendar days after the

Contractor knows of such requirements or the occurrence of such action or omission if the Contractor did not have such knowledge before the commencement of the work; or

3. Within thirty (30) calendar days after receipt of the written contract change order that was not agreed upon by both parties; or

4. Within such further time as may be allowed by the procurement officer in writing.

B. The notice shall clearly state the Contractor's intention to make claim and the reasons why the Contractor believes that additional compensation, changes or an extension of time may be remedies to which the Contractor is entitled; and afford the procurement officer every facility for keeping records of the actual cost of work. Failure on the part of the Contractor to give such notification or to afford the procurement officer proper facilities for keeping strict account of actual cost shall constitute waiver of the claim for such extra compensation. The filing of such notice by the Contractor and the keeping of costs by the procurement officer shall not in any way be construed to prove the validity of the claim.

The procurement officer will review the notice and render a decision. The procurement officer's decision shall be final and conclusive unless, within thirty (30) calendar days from the date of the decision, the Contractor mails or otherwise furnishes a written appeal to the Director. The decision of the Director shall be final. Later notification of such claims shall not bar the Contractor's claim unless the State is prejudiced by the delay in notification. No claim by the Contractor for an adjustment hereunder shall be allowed if notice is not given before final payment under this contract. Any adjustment in the contract price made pursuant to this clause shall be determined according to Section 4.5 - Price Adjustment.

The provisions of this Section shall not be construed as establishing any claims contrary to the terms of Section 4.4 - Changes and Claims for Adjustment.

Nothing herein contained, however, shall excuse the Contractor from compliance with any rules of law precluding any state officers and any Contractors from acting in collusion or bad faith in issuing or performing contract change orders which are clearly not within the scope of the contract.

SECTION 6 - CONTROL OF MATERIAL AND EQUIPMENT

6.1 DEFECTIVE MATERIALS - All materials not conforming to the requirements of these specifications or the special provisions shall be considered defective and all such materials, whether in place or not, shall be rejected. They shall be removed immediately from the site of the work, unless otherwise permitted by the Director. No rejected materials, the defects of which have been subsequently corrected, shall be used until approval in writing has been given by the Director. Upon failure on the part of the Contractor to comply promptly with any order to remove and replace defective materials, the Director may remove and replace defective material and to deduct the cost of removal and replacement from any monies due or to become due the Contractor.

6.2 TRADE NAMES AND ALTERNATES - For convenience in designation on the plans or in the specifications, certain equipment or articles or materials may be designated under a trade name or the name of a manufacturer and its information catalogue. The use of alternate equipment or an article or material which is of equal quality and of the required characteristics for the purposes intended will be permitted, subject to the written approval of the Director, in accordance with the following requirements:

A. QUALIFICATION BEFORE BID OPENING - When the specifications and/or plans specify one or more manufacturer's brand names of materials or equipment to indicate a quality, style, appearance, or performance, the bidder will be assumed to have based its bid on one of the specified named products, except where such proprietary product are specified, alternate brands may be qualified if found equal or better by the Director. Bidders requesting qualification of alternate proprietary products must submit a request to the Director for review and approval at the earliest date possible, but in any event, such request must be received at the Contracts office not later than ten (10) days before the bid opening date, not including the bid opening date.

It shall be the responsibility of the bidder to submit sufficient evidence based upon which a determination can be made by the Director that the alternate brand is qualified. The evidence shall be transmitted with a covering letter which shall list the evidence submitted and the items for which the substitution is requested.

If the evidence accompanying a request for substitution is insufficient to qualify a particular

model, the request shall be denied provided that further evidence may be submitted to qualify the item five (5) days prior to the bid opening date if the initial request was made prior to the deadline set above.

B. SUBSTITUTION AFTER BID OPENING - Substitution of material or equipment will not be allowed after the bid opening date except under the following unforeseen circumstances:

1. If a specified or pre qualified item is delayed by a lengthy strike in the factory or other unforeseeable contingency beyond the control of the Contractor which would cause an abnormal delay in the project completion.
2. If a specified or pre qualified item is found to be unusable due to change or other circumstances.
3. If the Contractor is willing to provide a more recently developed or manufactured item of material or equipment of the same manufacturer which the Director determines to be equal or better than the one specified or pre-qualified.

A substitution request, regardless of reason, shall be fully explained in writing by the Contractor and shall include its justification for said request, the quantities and unit prices involved, quotations and such other documents as are deemed necessary to support the request. Any savings in cost will accrue to the State and any additional cost for the substituted items will be paid by the Contractor.

The burden of proof as to the comparative quality and suitability of alternate equipment, articles, or materials shall be upon the bidder or Contractor and bidder or Contractor shall furnish, at its own expense, all information necessary or related thereto as required by the Director. The Director shall be the sole judge as to the comparative quality and suitability of alternate equipment, articles or materials and the Director's decisions shall be final.

The above shall not be construed to mean that substitution for brand name specified materials and equipment will be allowed; the Director reserves the right to deny any request he deems irregular or not in the best interest of the State.

6.3 ASSIGNMENT OF ANTITRUST CLAIMS FOR OVERCHARGES FOR GOODS AND MATERIALS PURCHASED

A. Vendor and purchaser recognize that in actual economic practice, overcharges resulting from antitrust violations are in fact usually borne by the purchaser. Therefore, vendor hereby assigns to purchaser any and all claims for such overcharges as to goods and materials purchased in connection with this order or contract, except as to overcharges which result from antitrust violations commencing after the price is established under this order or contract and which are not passed on to the purchaser under an escalation clause.

B. Contractor and owner recognize that in actual economic practice, overcharges resulting from antitrust violations are in fact usually borne by the owner. Therefore, contractor hereby assigns to owner any and all claims for such overcharges as to goods and materials purchased in connection with this order or contract, except as to overcharges which result from antitrust violations commencing after the price is established under this order or contract and any change order. In addition, contractor warrants and represents that each of its first tier suppliers and subcontractors shall assign any and all such claims to owner, subject to the aforementioned exception.

SECTION 7 - LEGAL RELATIONS AND RESPONSIBILITY

7.1 LAWS TO BE OBSERVED - The Contractor shall comply with all federal, state, city and county laws, ordinances, rules and regulations which in any manner affect those engaged or employed in the work, the materials used in the work, and the conduct of the work. Any reference to such laws, ordinances, rules and regulations shall include any amendments thereto effective as of the date of the call for sealed proposals.

The Contractor shall hold harmless, indemnify, defend and where appropriate, insure the State, its officers, agents and employees against any claim or liability arising from or based on the violation of any such laws, ordinances, rules or regulations. If any discrepancy or inconsistency is discovered in the contract for the work in relation to any law, ordinance, rule, regulation, order or decree, the Contractor shall forthwith report the same to the Director in writing.

7.2 PERMITS AND LICENSES - The Contractor shall procure all permits and licenses, pay all charges and fees, and give all notices necessary and incident to the due and lawful prosecution of the work.

7.3 PATENTS - The Contractor shall assume all costs arising from the use of patented materials, equipment, devices, or processes used on or incorporated in the work, and shall hold harmless, indemnify, defend and where appropriate, insure the State, its officers, agents and employees from all suits at law or actions of every nature, for or on account of the use of any patented materials, equipment, devices or processes.

7.4 RESPONSIBILITY FOR INJURY AND DAMAGE - The State, its officers, agents and employees shall not be held accountable in any manner for any loss or damage to the work or any part thereof, or for any of the materials and equipment used or employed in performing the work, or for any injury to any person or persons either workers or the public, or for any damage to property caused by the Contractor or its workers or any one employed by the Contractor. The Contractor shall be responsible for any liability imposed by law for any injury to any person or any damage to property resulting from defects or obstructions or from any cause whatsoever during the progress of the work or at any time before its completion and final acceptance. The acceptance of the completed work of the Contractor by the Director shall not relieve the Contractor from any liability which may have accrued or may accrue as a result of the performance of the work by the Contractor. The Contractor shall hold harmless, indemnify, defend and where appropriate, insure the State, its officers, agents and employees, from all suits or actions of every name, kind and description, brought for or on account of



any injuries or damages sustained by any persons or property caused by the Contractor, its servants or agents, or by or on account of any act or omission of the Contractor or its servants or agents, regardless of whether such actions or any claim is brought against them or any one of them before or after the final acceptance of the work. In addition to any remedy authorized by law, the State may withhold payment of any money due to Contractor as shall be reasonable until disposition has been made of any suits or claims for injuries or damages.

It is not the intention of the parties to this contract to make the public or any member thereof a third party beneficiary hereunder, or to authorize anyone not a party hereto to maintain a suit for personal injuries or property damage based on a contract theory of liability. In any event, the Contractor shall hold harmless, indemnify, defend and where appropriate, insure the State from suits and claims for personal injuries or property damage where such injuries or damage are caused by the negligent acts or omissions of the Contractor, its agents or employees.

7.5 COOPERATION BETWEEN CONTRACTORS - Where two or more Contractors are employed on related or adjacent work, each shall conduct its operations in such a manner as not to cause any unnecessary delay or hindrance to the other.

7.6 CONTRACTOR'S RESPONSIBILITY FOR WORK - Until the acceptance of the contract, the Contractor shall have the charge and care thereof and shall bear the risk of injury or damage to any part thereof by the action of the elements or from any other cause, whether arising from the execution or from the non-execution of the work. The Contractor shall rebuild, repair, restore, and make good all damages to any portion of the work occasioned by any of the above causes before its completion and acceptance and shall bear the expenses thereof.

7.7 NO PERSONAL LIABILITY - Neither the Director nor any other officer or authorized employee of the Department shall be personally responsible for any liability arising under the contract.

7.8 INSURANCE - Prior to commencing with the work, the Contractor shall, at its own expense, obtain and submit to the Department, Certificate of Insurance from an insurance company authorized by the laws of the State to issue such insurance in the State of Hawaii showing full policy coverage of the Contractor.

TYPES OF INSURANCE:

A. Workers' Compensation:

The Contractor shall obtain worker's compensation insurance for all persons whom they employ in carrying out the work under this contract. This insurance shall be in strict conformity with the requirements of the most current and applicable State of Hawaii Worker's Compensation Insurance laws in effect on the date of the execution of this contract and as modified during the duration of the contract. The minimum limit of liability for workers compensation is the HRS 386 statutory limit.

B. Comprehensive Automobile Liability:

The Contractor shall obtain Auto Liability Insurance covering all owned, non-owned and hired autos with a combined single Limit of not less than \$1,000,000 per accident for bodily injury and property damage with the State of Hawaii named as additional insured. The required limit of insurance may be provided by a single policy or with a combination of primary and excess policies.

C. Commercial General Liability:

The Contractor shall obtain General Liability insurance with a limit of not less than \$1,000,000 per occurrence and in the aggregates. The General liability insurance shall include the State of Hawaii as an additional insured. The required limit of insurance may be provided by a single policy or with a combination of primary and excess policies.

All policies must provide that 30 days prior written notice of cancellation or material change in coverage be given to certificate holders stated above.

Such insurance when accepted by the Director in writing shall become applicable and shall remain unmodified throughout the entire term of the contract and in no event shall be terminated or otherwise allowed to lapse prior to written certification of final acceptance of the work by the State. Such insurance aforementioned shall cover the State for all work performed under the contract, all work performed incidental thereto or directly or indirectly connected therewith, including other work performed outside of the work area, and all change orders.

Any delay in the submission and approval of insurance certificates shall not be justification of or grounds for a request by the Contractor postponing the issuance of a notice to proceed notwithstanding the fact that the Contractor shall not be allowed to proceed with the work until said certificates are submitted and approved.

Failure to obtain insurance in accordance with the Section, on the part of the Contractor, shall be considered a major breach of the contract; and should the State be forced to expend funds which would have been covered under the insurance, the Contractor agrees to assume the liability for such funds and to indemnify and hold the State harmless.

## SECTION 8 - PROSECUTION AND PROGRESS

8.1 PROGRESS OF WORK - The Contractor shall diligently prosecute the work to completion within the time limit specified in the proposal. The Contractor shall give its personal attention to the fulfillment of the contract and shall keep the work under its control. Work shall commence on the date indicated in the "Notice to Proceed" letter from the State.

8.2 LIQUIDATED DAMAGES - Time is of the essence in this contract and in case the Contractor fails to complete the work within the time specified in the proposal, damages will be sustained by the State. Since the amount of damages is difficult and not possible of definite ascertainment and proof, the amount of such damages are fixed in advance at the sum shown in the proposal for each and every calendar (or working) day which the Contractor has delayed in the completion of this contract; and the Contractor shall pay such amount as liquidated damages, and not by way of penalty, and in case the same are not paid, the State may deduct such amount thereof from any monies due or that may become due the Contractor under this contract.

If the Contractor finds it impossible for reasons beyond its control to complete the work within the contract time as specified, the Contractor shall, within 10 days from the first day of notification from the manufacturer or supplier of any delay and prior to the expiration of the contract time, make a written request to the Director for an extension of time setting forth therein the reasons which the Contractor believes will justify the granting of its request. The Contractor's plea that insufficient time was specified is not a valid reason for extension of time. If the Director finds that the work was delayed because of conditions beyond the control and without the fault of the Contractor, the Director may extend the time for completion in such extension as the conditions justify. The extended time for completion shall then be in full force and effect the same as though it were the original time for completion.

### 8.3 TEMPORARY SUSPENSION OF WORK

A. Order to stop work. The Director, may, by written order to the contractor, at any time, and without notice to any surety, require the contractor to stop all or any part of the work called for by this contract. This order shall be for a specified period not exceeding sixty (60) days after the order is delivered to the contractor, unless the parties agree to any further period. Any such order shall be identified specifically as a stop work order issued pursuant to this section. Upon receipt of such an order, the contractor shall forthwith comply with its terms and take all reasonable steps to minimize the occurrence of costs allocable to

the work covered by the order during the period of work stoppage. Before the stop work order expires, or within any further period to which the parties shall have agreed, the Director shall either:

1. Cancel the stop work order; or
2. Terminate the work covered by such order as provided in the "termination for default clause" or the "termination for convenience clause" of this contract.

B. Cancellation or expiration of the order. If a stop work order issued under this section is canceled or if the period of the order or any extension thereof expires, the contractor shall have the right to resume work. An appropriate adjustment shall be made in the delivery schedule or contract price, or both, and the contract shall be modified in writing accordingly; if:

1. The stop work order results in an increase in the time required for, or in the contractor's cost properly allocable to, the performance of any part of this contract; and
2. The contractor asserts a claim for such an adjustment within thirty (30) days after the end of the period of work stoppage; provided that, if the Director decides that the facts justify such action, any such claim asserted may be received and acted upon at any time prior to final payment under this contract.

C. Termination of stopped work. If a stop work order is not canceled and the work covered by such order is terminated for default or convenience, the reasonable costs resulting from the stop work order shall be allowable by adjustment or otherwise.

D. Adjustment of price. Any adjustment in contract price made pursuant to this clause shall be determined in accordance with the price adjustment clause of this contract.

#### 8.4 DEFAULT AND TERMINATION OF CONTRACT

A. Termination by Default. If the contractor refuses or fails to perform any of the provisions of this contract with such diligence as will ensure its completion within the time specified in this contract, or any extension thereof, otherwise fails to timely satisfy the contract provisions, or commits any other substantial breach of this contract, the Director may notify the contractor in writing of the delay or non-performance and if not cured in ten (10) days or any

longer time specified in writing by the Director, such officer may terminate the contractor's right to proceed with the contract or such part of the contract as to which there has been delay or a failure to properly perform. In the event of termination in whole or in part the Director may procure similar goods or services in the manner and upon terms deemed appropriate by the Director. The contractor shall continue performance of the contract to the extent it is not terminated and shall be liable for excess costs incurred in procuring similar goods or services.

1. Contractor's duties. Notwithstanding termination of the contract and subject to any directions from the Director, the contractor shall take timely, reasonable, and necessary action to protect and preserve property in the possession of the contractor in which the State or county has an interest.

2. Compensation. Payment for completed goods delivered and accepted by the State shall be at the contract price. Payment for the protection and preservation of property shall be in an amount agreed upon by the contractor and Director; if the parties fail to agree, the Director shall set an amount subject to the contractor's rights under chapter 3-126, HAR. The State may withhold from amounts due the contractor such sums as the Director deems to be necessary to protect the State against loss because of outstanding liens or claims of former lien holders and to reimburse the State for the excess costs incurred in procuring similar goods and services.

3. Excuse for nonperformance or delayed performance. Except with respect to defaults of subcontractors, the contractor shall not be in default by reason of any failure in performance of this contract in accordance with its terms, including any failure by the contractor to make progress in the prosecution of the work hereunder which endangers such performance, if the contractor has notified the Director within fifteen (15) days after the cause of the delay and the failure arises out of causes such as: acts of God; acts of the public enemy; acts of the State and any other governmental body in its sovereign or contractual capacity; fires; floods; epidemics; quarantine restrictions; strikes or other labor disputes; freight embargoes; or unusually severe weather. If the failure to perform is caused by the failure of a subcontractor to perform or to make progress, and if such failure arises out of causes similar to those set forth above, the contractor shall not be

deemed to be in default, unless the goods or services to be furnished by the subcontractor were unreasonably obtained from other sources in sufficient time to permit the contractor to meet the contract requirements. Upon request of the contractor, the Director shall ascertain the facts and extent of such failure, and if such officer determines that any failure to perform was occasioned by any one or more of the excusable causes, and that, but for the excusable cause, the contractor's progress and performance would have met the terms of the contract, the delivery schedule shall be revised accordingly, subject to the rights of the State under the clause entitled "Termination for Convenience". As used in this paragraph of this clause, the term "subcontractor" means subcontractor at any tier.

4. Erroneous termination for default. If, after notice of termination of the contractor's right to proceed under the provisions of this clause, it is determined for any reason that the contractor was not in default under the provisions of the clause, or that the delay was excusable under the provisions of paragraph (3), Excuse for nonperformance or delayed performance of this clause, the rights and obligations of the parties shall, if the contract contains a clause providing for termination for convenience of the State, be the same as if the notice of termination had been issued pursuant to such clause.

5. Additional rights and remedies. The rights and remedies provided in this clause are in addition to any other rights and remedies provided by law or under this contract.

B. Termination for convenience. The Director may, when the interests of the State so require, terminate this contract in whole or in part, for the convenience of the State. The Director shall give written notice of the termination to the contractor specifying the part of the contract terminated and when termination becomes effective.

1. Contractor's obligation. The contractor shall incur no further obligations in connection with the terminated work and on the dates set in the notice of termination the contractor will stop work to the extent specified. The contractor shall also terminate outstanding orders and subcontracts as they relate to the terminated work. The contractor shall settle the liabilities and claims arising out of the termination of subcontracts and orders connected with the terminated work. The Director

may direct the contractor to assign the contractor's right, title, and interest under terminated orders or subcontracts to the State. The contractor must still complete the work not terminated by the notice of termination and may incur obligations as are necessary to do so.

2. Right to goods. The Director may require the contractor to transfer title and deliver to the State in the manner and to the extent directed by the procurement officer:

- a. Any completed goods; and
- b. The partially completed goods and materials, parts, tools, dies, jigs, fixtures, plans, drawings, information, and contract rights hereinafter called "manufacturing material," as the contractor has specifically produced or specially acquired for the performance of the terminated part of this contract.

The contractor shall, upon direction of the Director, protect and preserve property in the possession of the contractor in which the State has an interest. If the Director does not exercise this right, the contractor shall use the contractor's best efforts to sell such goods and manufacturing materials. Use of this section in no way implies that the State has breached the contract by exercise of the termination for convenience clause.

3. Compensation:

- a. The contractor shall submit a termination claim specifying the amounts due because of the termination for convenience together with cost or pricing data to the extent required by subchapter 15, chapter 3-122, HAR, bearing on such claim. If the contractor fails to file a termination claim within one (1) year from the effective date of termination, the Director may pay the contractor, if at all, an amount set in accordance with subparagraph c. below.
- b. The Director and the contractor may agree to settlement provided the contractor has filed a termination claim supported by cost or pricing data to the extent required by subchapter 15, chapter 3-122, HAR, and that the settlement does not exceed the total contract price plus settlement costs reduced by payments previously made by the State, the



proceeds of any sales of goods and manufacturing materials under paragraph (2) of this clause, and the contract price of the work not terminated.

c. Absent complete agreement under subparagraph b above, the Director shall pay the contractor the following amounts, provided payments agreed to under subparagraph b. shall not duplicate payments under this subparagraph for the following:

(i) Contract prices for goods or services accepted under the contract;

(ii) Costs incurred in preparing to perform and performing the terminated portion of the work plus a fair and reasonable profit on such portion of the work, such profit shall not include anticipatory profit or consequential damages, less amounts paid or to be paid for accepted goods or services; provided that if it appears that the contractor would have sustained a loss if the entire contract would have been completed, no profit shall be allowed or included and the amount of compensation shall be reduced to reflect the anticipated rate of loss;

(iii) Costs of settling and paying claims arising out of the termination of subcontracts or orders pursuant to paragraph (1) of this clause. These costs must not include costs paid in accordance with subparagraph (ii) above.

(iv) The reasonable settlement costs of the contractor including accounting, legal, clerical, and other expenses reasonably necessary for the preparation of settlement claims and supporting data with respect to the terminated portion of the contract and for the termination of subcontracts thereunder, together with reasonable storage, transportation, and other costs incurred in connection with the protection or disposition of property allocable to the terminated portion of this contract. The total sum to be paid the contractor under this subparagraph shall not exceed the total contract price plus the reasonable settlement cost of the contractor reduced by the amount of

payments otherwise made, the proceeds of any sales of supplies and manufacturing materials under subparagraph b. of this paragraph, and the contract price of work not terminated.

d. Cost claimed, agreed to, or established under subparagraphs b. and c. shall be in accordance with chapter 3-123, H.A.R. bearing on such claim.

8.5 TERMINATION OF CONTRACTOR'S RESPONSIBILITY - The contract will be considered complete when all work has been completed, the work accepted by the Director, and the final estimate paid. The Contractor will then be released from further obligation except as set forth in the contract and bond, when applicable.

## SECTION 9 - PAYMENT

9.1 PAYMENT - The Contractor's bid price shall be inclusive of all costs, direct or indirect, including all taxes, required for the fulfillment of this contract.

Contract payments to the Contractor by the State shall be full payment, for furnishing all labor, and for furnishing and delivering all equipment, materials, supplies and other incidentals to the location(s) designated in these specifications.

9.2 PROGRESS PAYMENTS - If more than one shipment is required under these specifications, progress payments may be made to the Contractor after each shipment, provided the equipment materials, supplies, etc., furnished and delivered have satisfactorily met the requirements of these specifications. Five per cent (5%) of the amount of each progress payment shall be retained by the Department until the final acceptance of the work.

To expedite processing of all payments, for item(s) furnished and delivered to the Department, the Contractor shall forward an original and one copy of invoice with each shipment made to the recipient office.

Each invoice shall contain the following:

- A. Vendor's name, address and phone number.
- B. Contract or Purchase Order No.
- C. Description of item, the quantity, unit or lump sum price, sub-total and total.

9.3 FINAL ACCEPTANCE AND FINAL PAYMENT - Final acceptance means the acceptance in writing by the Director of the satisfactory completion of the work as provided under Section 8.5 followed by final payment in accordance with the Director's final estimate. The Department shall make final acceptance and payment promptly after the contract has been satisfactorily completed and final inspection made.

No payment will be made for any work which was not authorized by the Director in writing.

Final payment shall be made only after the issuance of the notice of final acceptance and after the Contractor has filed with the Director the following:

- A. Consent of the Contractor's surety, when applicable, of the final payment;

B. Satisfactory evidence by affidavit that all debts resulting from the contract have been fully paid or satisfactorily secured;

C. A current "Certificate of Vendor Compliance" issued by the Hawaii Compliance Express (HCE). The Certificate of Vendor Compliance is used to certify the Contractor's compliance with (a) Section 103D-328, HRS (for all contracts \$25,000 or more) which requires a current tax clearance certificate issued by the Hawaii State Department of Taxation and the Internal Revenue Service; (b) Chapters 383, 386, 392, and 393, HRS; and (c) Subsection 103D-310(c), HRS. The State reserves the right to verify that compliance is current prior to the issuance of final payment. Contractors are advised that non-compliance status will result in final payment being withheld until compliance is attained.

The filing of willfully false affidavits will disqualify the Contractor from bidding on future work of the Department.

SECTION 10 – FURNISHING AND DELIVERING TRAFFIC SIGNS

**10.1 DESCRIPTION OF WORK**

This work shall consist of furnishing and delivering traffic signs on an “as-needed” basis during the Contract period for the islands of Oahu, Hawaii, Maui and Kauai; and delivered to the place designated herein, all in accordance with the requirements of these Specifications, the Standard Specifications and the Standard Plans.

**10.2 GENERAL**

(A) Material.

1. Materials shall conform to the Standard Specifications, the Standard Plans and these Specifications.

<b>Material</b>	<b>Reference</b>
Traffic signs.	Standard Specification Section 750.01 except as amended in Section 10.2(A)1.a of this section.
	Standard Plans TE-04 through TE-08 and TE-11 and TE-12, as applicable.
Traffic signs backing.	Standard Specification Section 750.01(B) [ <i>“Aluminum sheet shall conform to ASTM B 209, alloy 5052-H38 or 6061-T6 flat sheet.”</i> ]. Amended Subsection 750.01(B) on 10/7/16 and can be found in <i>Appendix O</i> .

- a. Amendments to the Standard Specifications include the following changes to retroreflectorization:
  1. Retroreflectorization for Type III or IV retroreflective sheeting materials shall be in accordance with Section 750.01(C)(4), Type III or IV Retroreflective Sheeting (High Intensity) as amended by Section 750.01(E), Retroreflective Sheeting Materials dates 1/2/14.
  2. Retroreflectorization for Type XI retroreflective sheeting materials shall be in accordance with Section 750.01(A)(1), Retroreflectorization and 750.01(E), Retroreflective Sheeting Materials as amended on 1/2/14.
- b. Generals notes in the Standard Plans include specifications that sign details shall conform to the latest editions and their amendments of the following Federal Highway Administration publications:
  1. MUTCD for Streets and Highways.
  2. Standard Alphabets for Highway Signs.
  3. Standard Highway Signs.

- c. Refer to Section 10.6(C) Shop Drawings for additional requirements on non-standard traffic signs.

### **10.3 MINIMUM QUANTITY OF STORED MATERIALS**

- (A) Due to limited spaces in storage facilities in State baseyards, the Contractor shall store/stock a **minimum quantity/inventory of ten (10%) percent** of the estimated yearly quantity of each bid item in the Proposal Schedule in the Contractor's local storage facility. The stored items shall be readily available for furnishing and delivering to the State upon request and upon the issuance of a Purchase Order. The Contractor shall maintain the above-mentioned minimum quantity/inventory of stored/stocked materials by continued replenishment. Storing shall be incidental to the cost of furnishing and delivering the specified materials.
- (B) The State reserves the right to request the Contractor to furnish and deliver all estimated yearly quantity of each bid item in the Proposal Schedule upon the issuance of the Notice to Proceed or anytime during the term of the contract. When the State's order of materials exceeds the quantity of materials that is available in the Contractor's inventory in the local storage facility, the Contractor shall have a maximum of one hundred twenty (120) calendar days to deliver the remaining quantity.
- (C) To prolong the life of the specified materials, the Contractor shall protect the materials from the degradation effects of the weather and other elements or as prescribed by the manufacturer.

### **10.4 MINIMUM ORDER PER YEAR**

The State shall place a **minimum** order of materials per year, at a minimum dollar amount of thirty (30%) percent of the respective District's total estimated maximum yearly contract cost in the Proposal Schedule

### **10.5 DELIVERY**

- (A) Description.

"DELIVERY" shall mean transporting of the specified materials to the respective addresses below and unloading and stacking, as applicable, to a location as directed by the recipient State. The Contractor shall transport, unload and stack the specified material utilizing his or her own equipment and personnel or his or her subcontractor's equipment and personnel. Cost of "delivery" as defined above shall be incidental to the cost of furnishing and delivering the specified materials.

- (B) Coordination and Location of Deliver.

All deliveries under this contract shall be coordinated with the State or a duly authorized representative. Location of delivery and contact information is as follows:

District Engineer – Oahu District State DOT - Highways 727 Kakoi Street Honolulu, Hawaii 96819 Point of Contact: Mr. Mark Anama (Traffic Sign & Marking Subunit Supervisor – Oahu District) Phone No.: (808) 837-8054 Email: mark.t.anama@hawaii.gov	District Engineer – Hawaii District State DOT - Highways 50 Makaala Street Hilo, Hawaii 96720 Point of Contact: Mr. Francis Kekaulua (Const. & Maint. Superintendent – Hawaii District) Phone No.: (808) 933-8866 Email: francis.e.kekaulua@hawaii.gov
District Engineer – Maui District State DOT - Highways 650 Palapala Drive Kahului, Hawaii 96732 Point of Contact: Mr. Derek Takahashi (District Engineer – Maui District) Phone No.: (808) 873-3538 Email: derek.t.takahashi@hawaii.gov	District Engineer – Kauai District State DOT - Highways 1720 Haleukana Street Lihue, Hawaii 96766 Point of Contact: Mr. Eric Fujikawa (Design Engineer – Kauai District) Phone No.: (808) 241-3015 Email: eric.i.fujikawa@hawaii.gov

(C) Packaging and Marking.

The material shall be packaged in convenient size, clean manufactured containers and marked for shipment in accordance with the respective address as specified in Section 10.5.B Coordination and Location of Delivery, in the quantities indicated in the Purchase Order or Proposal, as applicable. All cases shall be labeled to allow quick identification of the contents. Labeling shall contain the following information:

- |                            |                           |
|----------------------------|---------------------------|
| 1. Material description    | 7. Contractor’s address   |
| 2. Size                    | 8. Manufacturer’s name    |
| 3. Count                   | 9. Manufacturer’s address |
| 4. Trademark or trade name | 10. Contract number       |
| 5. Date of manufacture     | 11. Project number        |
| 6. Contractor’s name       |                           |

The bid price shall include the cost of containers, which shall become the property of the Department. The Contractor shall replace any highway pavement marker and/or adhesive material which have become unfit for use.

(D) Delivery Period and Capability.

1. Sustained Delivery Capability.
  - a. Upon the issuance of Purchase Order from the State, the Contractor shall have a maximum of fourteen (14) calendar days to furnish and deliver any materials that is in storage at the Contractor’s local storage facility.

- b. When the State's order of materials exceeds the quantity of materials that is available in the Contractor's inventory in the local storage facility, the Contractor shall have a maximum of one hundred twenty (120) calendar days to deliver the remaining quantity.
- c. The Contractor shall maintain this sustained delivery capability through continued replenishment of inventory throughout the term of the contract.
- d. Refer to Section 8.2 Liquidated Damages for the amount that shall be assessed from the Contractor for failure to deliver in accordance with this Section.

(E) Notification of Delivery.

The Contractor shall have the shipper notify the recipient district by calling or emailing the point of contact as listed in Section 10.5.B Coordination and Location of Delivery of this section at least five (5) working days in advance as to the day and time of delivery. The day and time of delivery shall be subject to approval of the State.

(F) Inspection of Material.

The Contractor and the State shall make a visual and physical check of the materials delivered for damage, shortages, etc. Payment will not be processed until the Contractor and State have both concluded that the materials delivered meet the contract requirements.

**10.6 BIDDER/CONTRACTOR SUBMITTAL**

If requested by the State contractors may be asked to provide documentation for each of the material described and in accordance with the schedule as specified in Section 10.6.D Schedule of Submitting Required Documents of this section, the Contractor shall submit the following documents electronically.

**(A) Material Certificate of Compliance for traffic signs.**

- 1. The Contractor shall certify that the materials delivered conform to the requirements of the Standard Specifications, the Standard Plans, and these Specifications.
  - a. The notarized certificate shall include, as a minimum, the following data:
    - i. Name of manufacturer
    - ii. Material being certified
    - iii. Batch or lot number or Purchase Order Number as applicable
    - iv. Applicable test results of finished products
    - v. Applicable specifications
    - vi. Date
    - vii. Statement of compliance by a responsible official (employee) of the Manufacturer or by his representative. The Manufacturer's statement



of compliance shall be endorsed by the Contractor. Both manufacturer's statement of compliance and the Contractor's endorsement shall be notarized.

viii. Project identification

**(B) Warranty.**

1. For retroreflective sheeting materials used in the manufacturing of traffic signs, the manufacturer warrants that the coefficient of retroreflection for the reflective sheeting for traffic signage components for traffic control and guidance signs shall meet the **minimum** coefficient of retroreflection in accordance with the Standard Specifications in the table below.

	<b>Material</b>	<b>Reference</b>
1	High Intensity (Type III or IV) Prismatic Retroreflective Sheeting.	750.01(E), Retroreflective Sheeting Materials as amended on 10/7/16. <i>Refer to Appendix O</i>
2	Diamond Grade (Type XI) Retroreflective Sheeting.	750.01(E), Retroreflective Sheeting Materials as amended on 10/7/16. <i>Refer to Appendix O</i>

Such warranty or warranties shall be assigned to the State and submitted to the respective office as specified in Section 10.6 Bidder/Contractor Submittal.

**(C) Shop drawings.** Non-standard traffic signs in Appendices B through K shall be approved by the State.

**(D) Schedule of Submitting Required Documents.**

1. **Prior to award:** The Contractor shall electronically submit the Material Certificate of Compliance and Warranty to the Project Manager no later than seven (7) working days from the date of the written request by the State.

**Failure by the bidder to submit:** The bidder may be considered non-compliant with the requirements of the Specifications if the bidder fails to submit the specified documents later than seven (7) working days from the date requested by the State. This failure may result in bid rejection.

The Material Certificate of Compliance shall be reviewed by the Materials Testing & Research Branch and shall recommend acceptance or non-acceptance. The review process is estimated to be completed as early as five (5) working days and up to ten (10) working days from the time of receipt of the document(s). The Construction and Maintenance Branch shall send a letter or email to the Contractor stating those materials in the Certificate of Compliance are accepted or not accepted. If the material Certificate of Compliance is not accepted, it will be rejected and may result in bid rejection.

For each new order of materials, the Contractor shall require the manufacturer to furnish a material Certificate of Compliance. The Contractor shall furnish the certificate to the branch office as mentioned in Section 10.6 Bidder/Contractor Submittal and to the district offices (as applicable). Procedures for review and notifications shall be as specified in the paragraph above. Endorsement and notary shall be in accordance with Section 10.6(A)1.a.vii.

Pursuant to Section 106.01 Source of Supply and Quality Requirements, of the Standard Specifications, "All materials proposed to be used may be inspected and tested at any time and place including, but not limited to, the source of supply and locations of manufacture and fabrications.

If the State decides to test the specified materials, the Materials Testing and Research Branch will randomly select materials for testing from delivered materials from the district(s) and/or source of supply and locations of manufacture and fabrications. The Materials Testing and Research Branch will ship the samples to a third party testing facility and verify that the materials meet specifications.

2. **Prior to delivery:** The Contractor shall submit the Shop Drawings as specified in Section 10.6(C) of this section.
3. **Upon delivery:** The bidder shall submit the material Certificate of Compliance as specified in Section 10.6(A). Delivered materials that are not compliant with the contract specifications shall be replaced by the Contractor at no cost to the State.
4. **When there are changes to the composition or manufacturing process of any material as specified in this contract:** Throughout the life of the contract including any contract extension(s), report any changes, in writing, in the composition or manufacturing process of any material as specified in this contract to Construction and Maintenance Branch at the address as specified in this section. Any changes require a resubmission of Material Certificate of Compliance.

**10.7 TERM OF CONTRACT:** The term of this contract shall be for twelve (12) months from the date indicated on the Notice to Proceed from the State unless renewed as provided for in Section 10.8 Option to Extend Term, herein below.

**10.8 OPTION TO EXTEND TERM:** Subject to the availability of State funds, this contract may be extended up to four (4) additional twelve (12) month periods, or portions thereof, without the necessity for re-bidding upon mutual agreement between the State and the Contractor in writing provided the contract price for the extended period shall remain equal to or less than the initial bid price; with adjustments as provided in Section 10.9 Escalation Clause. The entire term of contract, including extensions, shall not exceed sixty (60) months.

## **10.9 ESCALATION CLAUSE:**

During the contract extension process, the State shall automatically adjust the unit bid prices of the Proposal Schedule to match the index percentage change in accordance to the sample computations below. The change in price, higher or lower, will be amended by a written contract amendment.

When evaluating the material escalation, the Producer Price Index (Aluminum mill shapes, WPU 102501) of the U.S. Department of Labor, Bureau of Labor Statistics shall be used to calculate percent change. The calculated percent change shall apply to the unit bid price when calculating escalation for the applicable bid items.

If the price of material increases or decreases by fifteen percent (15%) no adjustment to the existing unit bid item prices will be made. Once the price of the applicable material goes past the 15% threshold, the responsibility will shift to the State. If the adjustment to the unit bid item price exceeds fifteen percent (15%), the State will provide an escalation for the additional percent above 15 or delta. If the adjustment to the unit bid item price is decreased by more than fifteen percent (15%), the State would lower the original unit bid item price by the additional percent or delta. For example, if the percent increase was calculated to be 20, the contractor would have a total escalation of 5% after subtracting 15% from the calculated 20%. Thus, the extension would increase the previous terms unit bid item price five percent for all applicable bid items. Another example would be if the percent decrease was calculated to be -20%, the State would lower the original unit bid item price by 5% for all applicable bid items.

When computing calculations, the most recent data should be utilized even if it is preliminary data and compare it to the same month the previous year. Final calculated percentage should be rounded to the nearest whole number (.01 to .5 is rounded down and .51 to .99 is rounded up). Below are two sample computation examples on how the State will calculate percent change and apply it to the contract extension.

### Sample Computation Example No. 1: (Comparing April 2021 to April 2022 data)

Line	<b>Index Point Change and Percent Change</b>		
A	Furnished Good Prices <i>Index at the date of contract extension or date contract was written (current PPI)</i>	287.613 (New or Final Value)	April 2022 Value – Compare to same month previous year. Value can be found in red in the table below.
B	Less Previous Index <i>at the date of bid opening/previous contract extension</i>	211.0 (Original or Initial Value)	April 2021 Value Value can be found in red in the table below.
C	Equals Index Point Change $\frac{(Final\ Value) - (Initial\ Value)}{(Initial\ Value)}$	$\frac{287.613 - 211.0}{211.0} = 0.36309$	Calculate Percent Change.
D	Index Point Change Result multiplied by 100	$0.36309 \times 100 = 36.31\%$ (Percent change can be positive or negative)	Equals percent change. (36.31% rounds to 36.00%)

Sample Computation Example No. 1: Continued:

E	<p>Equals percent change above or below 15.0%. When percentage is above or below 15 percent perform calculation otherwise not needed.</p> <p>This will be the <b>final value</b></p>	<p><math>36.00\% - 15.00\% = 21.00\%</math></p> <p>(When percent change is negative add 15% When percent change is positive subtract 15%)</p>	<p><b>This example the State will provide any escalation of 21.00% to the existing unit bid prices.</b> Final calculated percent change should be rounded to the nearest whole number.</p> <p>Final Value = 21.00% when rounded. (.01 to .5 is rounded down and .51 to .99 is rounded up)</p>
---	--------------------------------------------------------------------------------------------------------------------------------------------------------------------------------------	---------------------------------------------------------------------------------------------------------------------------------------------------	---------------------------------------------------------------------------------------------------------------------------------------------------------------------------------------------------------------------------------------------------------------------------------------------------

Sample Computation Example No. 2: (Comparing April 2022 to April 2023 data)

Line	Index Point Change and Percent Change		
A	Furnished Good Prices <i>Index at the date of contract extension or date contract was written (current PPI)</i>	235.988(P)  (Final Value)	April 2023 Value – Compare to the same month previous year. Values can be found in table below.
B	Less Previous Index <i>at the date of bid opening/previous contract extension</i>	287.613  (Initial Value)	April 2022 Value
C	Equals Index Point Change <i><math>\frac{(Final Value) - (Initial Value)}{(Initial Value)}</math></i>	$\frac{235.988 - 287.613}{287.613} = -0.17949$	Calculate Percent Change
D	Index Point Change Result multiplied by 100	$-0.1794 \times 100 = -17.94\%$ (Percent change can be positive or negative)	Equals percent change.  (-17.94% rounds to 18.00%)
E	<p>Equals percent change above or below 15.0%. When percentage is above or below 15 percent perform calculation otherwise not needed.</p> <p>This will be the <b>final value</b></p>	<p><math>-18.0\% \pm 15 = -3.0\%</math></p> <p>(When percent change is negative add 15% When percent change is positive subtract 15%)</p>	<p><b>This example the State will lower the existing unit prices by 3%.</b> Final calculated percent change should be rounded to the nearest whole number. (.01 to .5 is rounded down and .51 and above is rounded up)</p>

For more information on Producer Price Index, log on to the following links:

1. [https://data.bls.gov/timeseries/WPU102501?amp%253bdata\\_tool=XGtable&output\\_view=da ta&include\\_graphs=true](https://data.bls.gov/timeseries/WPU102501?amp%253bdata_tool=XGtable&output_view=da ta&include_graphs=true)
2. <https://www.bls.gov/ppi/faqs/questions-and-answers.htm> for the frequently asked questions.

Table Referenced for Sample Computation No. 1 & 2 Values (Item: Aluminum mill shapes WPU102501)

Year	Jan	Feb	Mar	Apr	May	Jun	Jul	Aug	Sep	Oct	Nov	Dec
2018	189.0	193.7	197.8	201.1	211.1	214.5	208.5	206.2	204.4	204.2	202.2	200.5
2019	201.2	201.0	201.4	202.5	200.6	198.8	198.4	195.3	194.2	193.7	191.4	191.7
2020	192.3	187.9	185.7	177.9	171.1	169.4	172.0	175.8	182.4	181.8	182.4	188.4
2021	193.5	196.4	200.3	211.0	218.4	226.0	226.843	235.604	243.212	253.771	258.862	244.037
2022	253.817	271.422	278.240	287.613	278.597	262.278	250.971	242.087	238.823	231.681	228.166	231.131
2023	236.333	240.325	240.372(P)	235.988(P)	237.308(P)	234.227(P)						

P : Preliminary. All indexes are subject to monthly revisions up to four months after original publication.

**10.10 BASIS FOR PAYMENT**

- (A) Traffic signs shall be paid for at the contract price per unit, which respective price will be full compensation for all materials, labor, equipment, applicable taxes and incidentals necessary to manufacture and fabricate the specified items, all in accordance with these specifications to furnish and deliver the specified items to the places designated in Section 10.5.B Coordination and Location of Delivery.

Incidental costs include, but not limited to the following:

Item	Reference
Storage of materials	Section 10.3(A)
Cost of delivery (transporting, unloading, and stacking)	Section 10.5(A)

- (B) Payments for purchases made will be made by Purchase Order as specified in Section 4.6 Contract To Be Indefinite Quantity. Refer to Section 9.2 Progress Payments, of the Special Provisions, for additional information on Purchase Orders and processing invoices.

STATE OF HAWAII  
DEPARTMENT OF TRANSPORTATION  
HIGHWAYS  
HONOLULU, HAWAII

APPENDICES

Contents:

- Appendix A Standard Plan
- Appendix B Non-standard sign, “Unlawful to Litter \$1000 Fine”
- Appendix C Non-standard sign, “No Camping”
- Appendix D Non-standard sign, “Bicycle (symbol) Lane Ahead”
- Appendix D1 Non-standard sign, “No Right Turn On Red Except From Right Lane After Stop”
- Appendix E Non-standard sign, “Trucks Test Brakes”
- Appendix E1 Non-standard sign, “On Left Arrow Only U Turn OK”
- Appendix E2 Non-standard sign, “On Left Arrow Only No U Turn”
- Appendix E3 Non-standard sign, “On Left Arrow Only”
- Appendix E4 Non-standard sign, “On Left Arrow Only U Turn OK
- Appendix F Non-standard sign, “On Left Arrow Only No U Turn
- Appendix G Non-standard sign, “No Dumping”
- Appendix G1 Non-standard sign, “No Jumping From Bridge”
- Appendix G2 Non-standard sign, “No Vending”

- Appendix G3 Non-standard sign, “Keep Out Government Property Trespassers Will Be Prosecuted State Department of Transportation Highways Division HRS 264-12, HRS 264-6, HRS 708-815”
- Appendix H Non-standard sign, “Truck Crossing When Flashing”
- Appendix I Non-standard sign, “Rumble Strips Ahead”
- Appendix II Non-standard sign, Clearance Marker
- Appendix J Non-standard sign, “Adopt a Highway Litter Control Next 2 Miles”
- Appendix K Modified MUTCD Sign, “Ahupua‘a”
- Appendix L Modified MUTCD Sign, “Watch for Pedestrians”
- Appendix M Modified MUTCD Sign, “School Xing”
- Appendix N Modified MUTCD Sign, “Stop Ahead”
- Appendix O Amended Section 750.01(B) Traffic Control Sign and Marker Materials
- Appendix P Sample – Monthly Invoice
- Appendix Q Sample – Satisfactory Evidence by Affidavit for Final Payment

# Appendix A

 R1-1 30"x30" R1-1-A 36"x36"	 R1-2 36"x36"x36" R1-2-A 48"x48"x48"	 R2-1(50) 24"x30" R2-1(50)-A 48"x60" R2-1(50)-B 36"x48"	 R2-2(40) 24"x24" R2-2(40)-A 48"x48"	 R2-4a(50/40) 24"x48" R2-4a(50/40)-A 48"x96"	 R3-1 24"x24" 24"x18" R3-1-A 48"x48" 48"x36"	 R3-2 24"x24" 24"x18" R3-2-A 48"x48" 48"x36"	 R3-3 24"x24" R3-3-A 48"x48"	 R3-4 24"x24" 24"x18" R3-4-A 48"x48" 48"x36"	 R3-5(L) 30"x36" R3-5(L)-A 48"x60"	 R3-6(L) 30"x36" R3-6(L)-A 48"x60"	 R3-7(R) 30"x30" R3-7(R)-A 48"x48"
 R1-3 12"x6" R1-3-A 18"x9"	 R1-4 18"x6" R1-4-A 24"x9"										
 R3-8(L) 30"x30" R3-8(L)-A 36"x36" R3-8(L)-B 48"x48"	 R3-9a 30"x36"	 R4-1 24"x30" R4-1-A 48"x60"	 R4-2 24"x30" R4-2-A 48"x60"	 R4-3 24"x30" R4-3-A 48"x60"	 R4-5 24"x30" R4-5-A 48"x60"	 R4-6(500) 24"x30" R4-6(500)-A 48"x60"	 R4-7 24"x30" 24"x18" R4-7-A 48"x60"	 R4-8 24"x30" 24"x18" R4-8-A 48"x60"	 R5-1 30"x30" R5-1-A 48"x48"	 R5-1a 36"x24"	 R5-2 24"x24" 24"x18"
 R5-4 24"x30" R5-4-A 48"x60"	 R5-6 24"x24" 24"x18"	 R6-1(R) 36"x12"	 R6-2(R) 24"x30"	 R7-1 12"x18" R7-1-A 24"x30"	 R7-4 12"x18" R7-4-A 24"x30"	 R7-107(R) 12"x18"	 R7-108 12"x18"	 R7-201 12"x6" R7-201-A 24"x12"	 R8-1 24"x30" R8-1-A 48"x60"	 R8-2 24"x30" R8-2-A 48"x60"	 R8-3 24"x30" R8-3-A 48"x48"
 R8-4 30"x24" R8-4-A 48"x36"	 R8-5 24"x30" R8-5-A 48"x60"	 R8-6 24"x30" R8-6-A 48"x60"	 R8-7 30"x24" R8-7-A 48"x36"	 R9-1 18"x24"	 R9-2 12"x18"	 R9-3 12"x18"	 R9-4 18"x24"	 R10-1 12"x18"	 R10-2 12"x18"	 R10-3 9"x12"	 R10-4 9"x12"
 R10-5 24"x30"	 R10-6 24"x36"	 R10-7 24"x30"	 R10-8 24"x30"	 R10-9 24"x30"	 R10-10 24"x30"	 R10-12 24"x30"					
 R10-17a 30"x36"	 R11-1 24"x30"	 R11-2 48"x30"	 R11-3(10) 60"x30"	 R11-4 60"x30"	 R12-1(10) 24"x30"						

## GENERAL NOTES

1. Sign details shall conform to the latest editions of FHWA publications "Manual on Uniform Traffic Control Devices for Streets and Highways," "Standard Alphabets for Highway Signs," and "Standard Highway Signs," and as amended.
2. All regulatory signs shall be reflectorized unless otherwise specified.
3. All regulatory signs shall have 3/8" bolt holes drilled at appropriate locations.
4. Numerals in ( ) indicate numerals to be inserted for sign message. (R) or (L) indicates right or left.
5. All signs shall be erected without educational plaques unless called for in the plans.

00/00/00	X	
DATE	REVISION	APP'D.















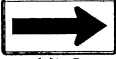







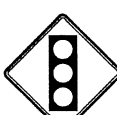















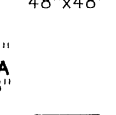

STATE OF HAWAII  
DEPARTMENT OF TRANSPORTATION  
HIGHWAYS DIVISION

**STANDARD PLAN TE-04**

**REGULATORY SIGNS**

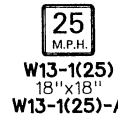
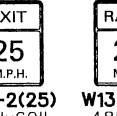

# Appendix A (continuation)

 <b>W1-1(R)</b> 30"x30" <b>W1-1(R)-A</b> 48"x48"	 <b>W1-2(R)</b> 30"x30" <b>W1-2(R)-A</b> 48"x48"	 <b>W1-3(R)</b> 30"x30" <b>W1-3(R)-A</b> 48"x48"	 <b>W1-4(R)</b> 30"x30" <b>W1-4(R)-A</b> 48"x48"	 <b>W1-5(R)</b> 30"x30" <b>W1-5(R)-A</b> 48"x48"	 <b>W1-6</b> 48"x24"   <b>W1-7</b> 48"x24"	 <b>W2-1</b> 30"x30" <b>W2-1-A</b> 48"x48"	 <b>W2-2(R)</b> 30"x30" <b>W2-2(R)-A</b> 48"x48"	 <b>W2-3(R)</b> 30"x30" <b>W2-3(R)-A</b> 48"x48"	 <b>W2-4</b> 30"x30" <b>W2-4-A</b> 48"x48"						
 <b>W2-5</b> 30"x30" <b>W2-5-A</b> 48"x48"	 <b>STOP AHEAD</b> <b>W3-1</b> 36"x36" 24"x18" <b>W3-1-A</b> 48"x48" 24"x18"	 <b>YIELD AHEAD</b> <b>W3-2</b> 36"x36" 24"x18" <b>W3-2-A</b> 48"x48" 24"x18"	 <b>SIGNAL AHEAD</b> <b>W3-3</b> 36"x36" 24"x18" <b>W3-3-A</b> 48"x48" 24"x18"	 <b>SPEED LIMIT 25</b> <b>W3-5(25)</b> 36"x36" <b>W3-5(25)-A</b> 48"x48"	 <b>MERGE</b> <b>W4-1(R)</b> 36"x36" 24"x18" <b>W4-1(R)-A</b> 48"x48" 24"x18"	 <b>W4-2(R)</b> 36"x36" <b>W4-2(R)-A</b> 48"x48"	 <b>ROAD NARROWS</b> <b>W5-1</b> 36"x36" <b>W5-1-A</b> 48"x48"	 <b>NARROW BRIDGE</b> <b>W5-2</b> 36"x36" <b>W5-2-A</b> 48"x48"	 <b>ONE LANE BRIDGE</b> <b>W5-3</b> 36"x36" <b>W5-3-A</b> 48"x48"						
 <b>DIVIDED HIGHWAY</b> <b>W6-1</b> 36"x36" 24"x18" <b>W6-1-A</b> 48"x48" 24"x18"	 <b>DIVIDED HIGHWAY ENDS</b> <b>W6-2</b> 36"x36" 24"x18" <b>W6-2-A</b> 48"x48" 24"x18"	 <b>TWO WAY TRAFFIC</b> <b>W6-3</b> 36"x36" 24"x18" <b>W6-3-A</b> 48"x48" 24"x18"	 <b>HILL</b> <b>W7-1</b> 30"x30" 24"x18" <b>W7-1-A</b> 48"x48" 24"x18"	 <b>USE LOW GEAR</b> <b>W7-2</b> 24"x18"	 <b>DIP</b> <b>W8-2</b> 30"x30" <b>W8-2-A</b> 36"x36" <b>W8-2-B</b> 48"x48"	 <b>PAVEMENT ENDS</b> <b>W8-3</b> 36"x36" <b>W8-3-A</b> 48"x48"	 <b>SOFT SHOULDER</b> <b>W8-4</b> 30"x30" <b>W8-4-A</b> 36"x36"	 <b>SLIPPERY WHEN WET</b> <b>W8-5</b> 30"x30" 24"x18" <b>W8-5-A</b> 48"x48" 24"x18"	 <b>RIGHT LANE ENDS</b> <b>W9-1(R)</b> 30"x30" <b>W9-1(R)-A</b> 36"x36" <b>W9-1(R)-B</b> 48"x48"						
 <b>LANE ENDS MERGE LEFT</b> <b>W9-2(L)</b> 36"x36" <b>W9-2(L)-A</b> 48"x48"	 <b>W10-1</b> 36" Diameter	 <b>BIKE XING</b> <b>W11-1</b> 30"x30" 24"x18" <b>W11-1-A</b> 36"x36" 24"x18" <b>W11-1-B</b> 48"x48"	 <b>AHEAD</b> <b>W11-2</b> 36"x36" <b>W11-2-A</b> 48"x48"	 <b>W11-2</b> 36"x36" <b>W11-2-A</b> 48"x48"	 <b>CATTLE XING</b> <b>W11-4</b> 30"x30" 24"x18" <b>W11-4-A</b> 36"x36" 24"x18" <b>W11-4-B</b> 48"x48" 24"x18"	 <b>FARM MACHINERY</b> <b>W11-5</b> 30"x30" 24"x18" <b>W11-5-A</b> 36"x36" 24"x18" <b>W11-5-B</b> 48"x48"	<b>GENERAL NOTES</b> 1. Sign details shall conform to the latest editions of FHWA publications "Manual on Uniform Traffic Control Devices for Streets and Highways," "Standard Alphabets for Highway Signs" and "Standard Highway Signs", and as amended. 2. All warning signs shall be reflectorized unless otherwise specified. 3. All warning signs shall have 3/8" bolt holes drilled at appropriate locations. 4. Numerals in ( ) indicate numerals to be inserted for sign message. (R) or (L) indicates right or left. 5. Signs prefixed with "CW" on the plans shall indicate orange and black construction signs and shall be reflectorized.								
 <b>W12-1</b> 36"x36" <b>W12-1-A</b> 48"x48"	 <b>LOW CLEARANCE</b> <b>W12-2(12'-6")</b> 36"x36" 24"x18" <b>W12-2(12'-6")-A</b> 48"x48" 24"x18"	 <b>25 M.P.H.</b> <b>W13-1(25)</b> 18"x18" <b>W13-1(25)-A</b> 24"x24"	 <b>EXIT 25 M.P.H.</b> <b>W13-2(25)</b> 48"x60"	 <b>RAMP 25 M.P.H.</b> <b>W13-3(25)</b> 48"x60"	 <b>DEAD END</b> <b>W14-1</b> 30"x30" <b>W14-1-A</b> 36"x36"	 <b>NO PASSING ZONE</b> <b>W14-3</b> 36"x48"x48" <b>W14-3-A</b> 48"x64"x64"	<table border="1" style="width: 100%; border-collapse: collapse;"> <tr> <td style="width: 33%; text-align: center;">00/00/00 X</td> <td style="width: 33%;"></td> <td style="width: 33%;"></td> </tr> <tr> <td style="text-align: center;">DATE</td> <td style="text-align: center;">REVISION</td> <td style="text-align: center;">APP'D.</td> </tr> </table>			00/00/00 X			DATE	REVISION	APP'D.
00/00/00 X															
DATE	REVISION	APP'D.													

STATE OF HAWAII  
DEPARTMENT OF TRANSPORTATION  
HIGHWAYS DIVISION

STANDARD PLAN TE-05

WARNING SIGNS

# Appendix A (continuation)



**R2-5a**  
24"x30"  
**R2-5a-A**  
48"x60"



**R2-10**  
24"x30"  
4"Ser.D  
4"Ser.D  
4"Ser.C  
3"Ser.D  
5"Ser.C



**R3-9b**  
24"x36"



**R5-8**  
30"x24"  
4"Ser.B



**R7-107a**  
12"x30"



**R7-8**  
12"x18"  
**R7-8-A**  
24"x30"



1/2" 4"Ser.C  
**R8-3a**  
24"x24"  
24"x18"  
**R8-3a-A**  
48"x48"  
24"x18"



**R9-3a**  
18"x18"  
18"x12"  
**R9-3a-A**  
24"x24"  
24"x18"



**R9-3b(R)**  
18"x12"



**R9-3b(L)**  
18"x12"



**R10-11a**  
24"x30"



**R16-2**  
24"x30"  
4"Ser.C



4"Ser.D  
3"Ser.D  
2"Ser.D  
3"Ser.D  
**R16-3**  
18"x24"



**R16-4**  
18"x24"

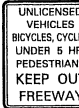

3"Ser.C  
4"Ser.E  
**R16-5**  
36"x42"



**R16-6**  
24"x30"  
8"Ser.F  
5"Ser.D



**R16-7**  
24"x30"



**R18-1**  
24"x18"  
4"Ser.C



**W1-8(R)**  
18"x24"  
**W1-8(R)-A**  
30"x36"  
**W1-8(R)-B**  
36"x48"  
6"Ser.C

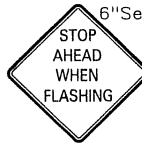

**W3-4**  
48"x48"



**W4-3(R)**  
36"x36"  
**W4-3(R)-A**  
48"x48"

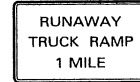

**W7-4**  
78"x48"



**W7-4b**  
78"x60"



**W8-6**  
30"x30"  
**W8-6-A**  
36"x36"  
**W8-6-B**  
48"x48"



**W4-7(L)**  
48"x48"  
6"Ser.E



**W11-7**  
36"x36"  
24"x18"  
**W11-7-A**  
48"x48"  
24"x18"



**W11-8**  
36"x36"  
24"x18"  
**W11-8-A**  
48"x48"  
24"x18"



**W11-9**  
36"x36"  
**W11-9-A**  
48"x48"



**W14-2**  
30"x30"



**W14-4**  
36"x36"  
**W14-4-A**  
48"x48"



**W15-1**  
36"x36"

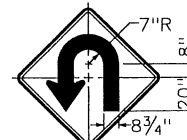

**W17-2(L)**  
60"x60"  
7"R  
20"R  
8 3/4"



**W18-1**  
48"x60"  
8"Ser.E



**CW16-1(1/2)**  
60"x60"  
8"Ser.E



**W16-9p**  
24"x12"  
**W16-9p-A**  
30"x18"  
**W16-9p-B**  
36"x24"  
36"x36"  
**S1-1**  
**S1-1-A**  
48"x48"



**S3-1**  
30"x30"  
**S3-1-A**  
36"x36"



**S4-1**  
24"x10"



**S4-2**  
24"x10"



**S4-3**  
24"x8"



**S4-4**  
24"x10"

## GENERAL NOTES

- Sign details shall conform to the latest editions of the following FHWA publications:
  - "Standard Alphabets for Highway Signs," and as amended.
  - "Standard Highway Signs," and as amended.
  - "Manual on Uniform Traffic Control Devices for Streets and Highways," and as amended.
- All signs shall be reflectorized with reflective sheeting, unless otherwise specified.
- All signs shall have 3/8" bolt holes drilled at appropriate locations.
- Numerals in ( ) indicate numerals to be inserted for sign message. (R) or (L) indicates right or left.
- Signs prefixed with "CW" on the plans shall indicate orange and black construction signs, and shall be reflectorized with reflective sheeting.
- All signs shall be erected without educational plaques unless called for in the plans.

00/00/00	X	
DATE	REVISION	APP'D.

STATE OF HAWAII  
DEPARTMENT OF TRANSPORTATION  
HIGHWAYS DIVISION

**STANDARD PLAN TE-06**

MISCELLANEOUS SIGNS

# Appendix A

(continuation)



**CW20-1Ad**  
48"x48"



**CW20-1**  
(1 MILE)  
48"x48"



**CW20-1a**  
48"x48"



**CW20-2d**  
48"x48"



**CW20-3b**  
48"x48"



**CW20-4d**  
48"x48"



**CW20-5d(L)**  
48"x48"



**500 FEET**  
**CW20-7a**  
36"x36"  
24"x18"  
**CW20-7a-A**  
48"x48"  
24"x18"



**CW21-1**  
36"x36"  
**CW21-1-A**  
48"x48"



**CW21-2**  
30"x30"



**CW21-3**  
36"x36"



**CW21-5**  
30"x30"  
**CW21-5-A**  
48"x48"



**CW21-6**  
30"x30"



**CW22-1b**  
48"x48"



**CW22-2**  
48"x36"

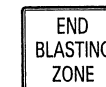

**CW22-3**  
42"x36"



**CW8-6**  
36"x36"



**CW23-2b**  
48"x48"



**CW23-3(R)**  
48"x48"

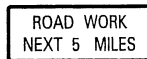

**CG20-1A(5)**  
60"x24"

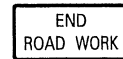

**CG20-2A**  
48"x24"



**CG20-4**  
36"x18"



**CM4-9(R)**  
30"x24"



**CM4-10(R)**  
48"x18"

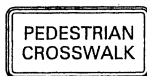

**R9-8**  
36"x18"

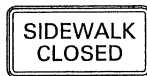

**R9-9**  
24"x12"

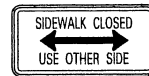

**R9-10**  
24"x12"



**R9-11**  
24"x12"

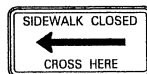

**R9-11a**  
24"x12"

### GENERAL NOTES

1. Sign details shall conform to the latest editions of FHWA publications "Manual on Uniform Traffic Control Devices for Streets and Highways", "Standard Alphabets for Highway Signs" and "Standard Highway Signs", and as amended.
2. All construction signs shall be reflectorized.
3. All construction signs shall have 3/8" bolt holes drilled at appropriate locations.
4. Numerals in ( ) indicate numerals to be inserted for sign message. (R) or (L) indicates right or left.
5. For "CW" series signs, suffixes a,b,c and d are as follows:  
a-1500 Ft., b-1000 Ft., c-500 Ft. and d-AHEAD.

00/00/00	X		
DATE	REVISION	APP'D.	

STATE OF HAWAII  
DEPARTMENT OF TRANSPORTATION  
HIGHWAYS DIVISION

STANDARD PLAN TE-07

CONSTRUCTION SIGNS



# Appendix A (continuation)

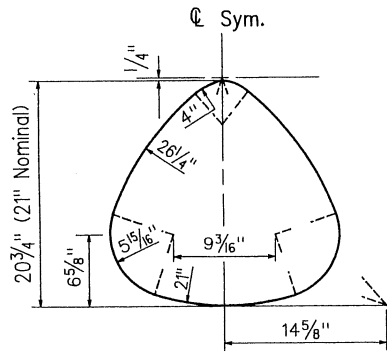

STATE ROUTE MARKER DETAIL

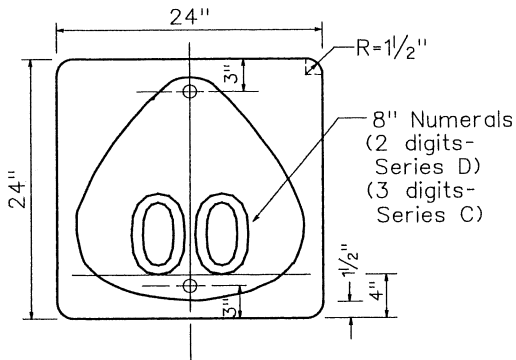

M1-6(00)  
24"x24"

STATE ROUTE MARKER



M2-1  
21"x15"

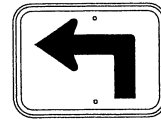

M5-1(L)  
21"x15"

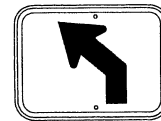

M5-2(L)  
21"x15"

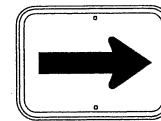

M6-1(R)  
21"x15"



M6-2(R)  
21"x15"



M6-3  
21"x15"

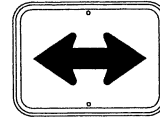

M6-4  
21"x15"

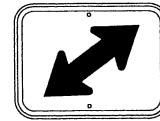

M6-5(R)  
21"x15"

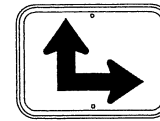

M6-6(R)  
21"x15"

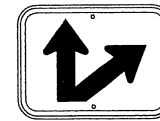

M6-7(R)  
21"x15"



M3-1 24"x12"  
M3-1-A 36"x18"



M4-1  
24"x12"

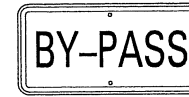

M4-2  
24"x12"



M4-3  
24"x12"

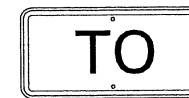

M4-5  
24"x12"

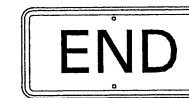

M4-6  
24"x12"

## GENERAL NOTES

1. Marker details shall conform to the latest editions of FHWA publications "Manual on Uniform Traffic Control Devices for Streets and Highways", "Standard Alphabets for Highway Signs" and "Standard Highway Signs" and as amended.
2. All markers shall be reflectorized unless otherwise specified.
3. All markers shall have 3/8" bolt holes drilled at appropriate locations.
4. Numerals in ( ) indicate numerals to be inserted for marker message. (R) or (L) indicates right or left.
5. Sign message of Cardinal Direction Marker (M3 series) shall be denoted by the following:

M3-1: NORTH  
M3-2: EAST  
M3-3: SOUTH  
M3-4: WEST

6. Markers prefixed with "IM" on the plans shall have a white legend on a blue background.



M4-7  
24"x12"

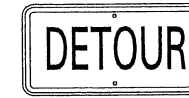

M4-8  
24"x12"

## AUXILIARY MARKERS

00/00/00	X	
DATE	REVISION	APP'D.

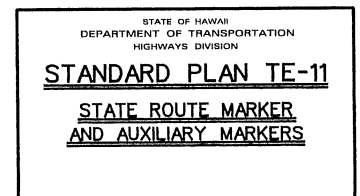

# Appendix A

(continuation)

MARKER SIZE	MULTIPLY DIMENTIONS BY	NUMERAL SIZE
		2 Digit-Series D 3 Digit-Series C
21"	1.3	8"
32"	2.0	12"
42"	2.63	16"

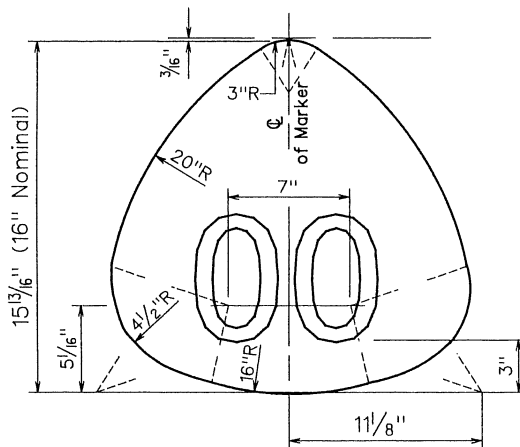

STATE ROUTE MARKER  
FOR GUIDE SIGNS

NOTE:

1. State Route Markers on Guide signs shall have black numerals on a white reflectorized background mounted on a flat aluminum cut-out.
2. Numerals shall conform to the latest editions of FHWA publication "Standard Alphabets for Highway Signs" and as amended.
3. Cut-outs shall be fastened on sign panel with aluminum blind rivets. See Standard Specifications.

RADII FOR SIGNS		
Least Dimension of Sign	W	R
2'-0" to 4'-6"	2"	3"
4'-9" to 5' 6"	2"	6"
5'-9" to 7'-6"	2"	9"
7'-9" and greater	2"	12"

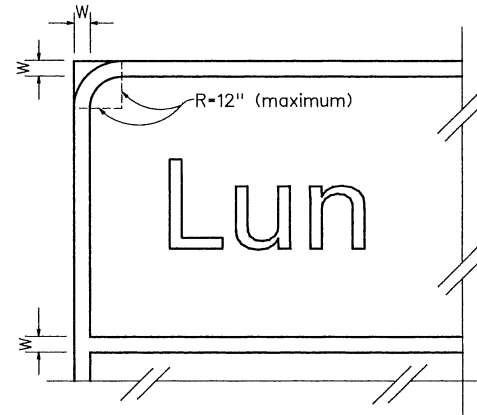

BORDER DETAIL  
FOR GUIDE SIGNS

NOTE:

1. Area outside corner radius need not be trimmed.
2. All borders shall be white reflectorized cut-outs.
3. All Guide signs shall have borders.

00/00/00	X	
DATE	REVISION	APP'D.

STATE OF HAWAII DEPARTMENT OF TRANSPORTATION HIGHWAYS DIVISION
<b>STANDARD PLAN TE-12</b>
<b>STATE ROUTE MARKER AND</b>
<b>BORDER DETAIL FOR GUIDE SIGNS</b>

# Appendix B

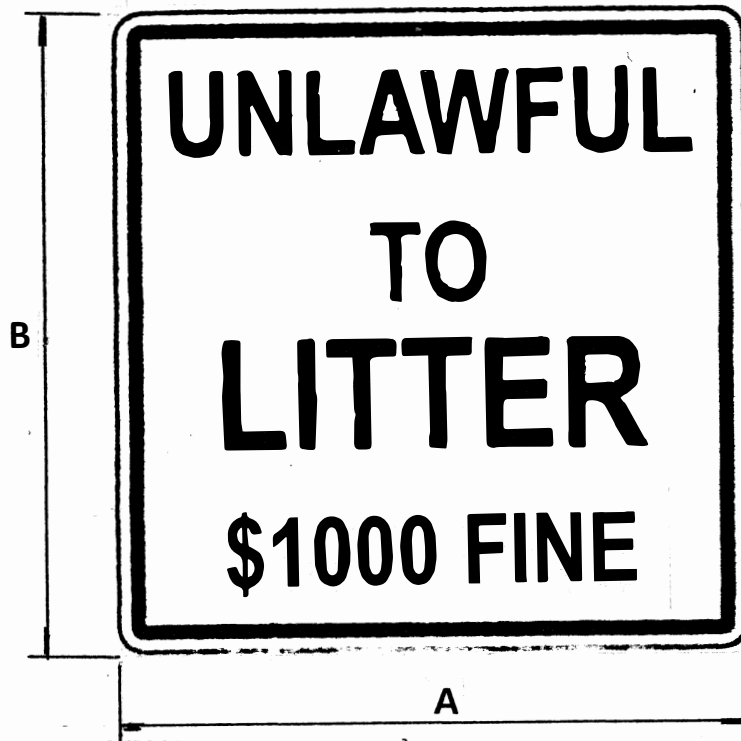

NON-STANDARD  
UNLAWFUL TO LITTER \$1000 FINE

A	B
24"	30"

COLORS	LEGEND:	BLACK
	BACKGROUND:	WHITE (HIGH INTENSITY PRISMATIC)

# Appendix C



NON-STANDARD  
NO CAMPING

A	B
24"	18"

COLORS	LEGEND:	RED
	BACKGROUND:	WHITE (HIGH INTENSITY PRISMATIC)



Appendix D

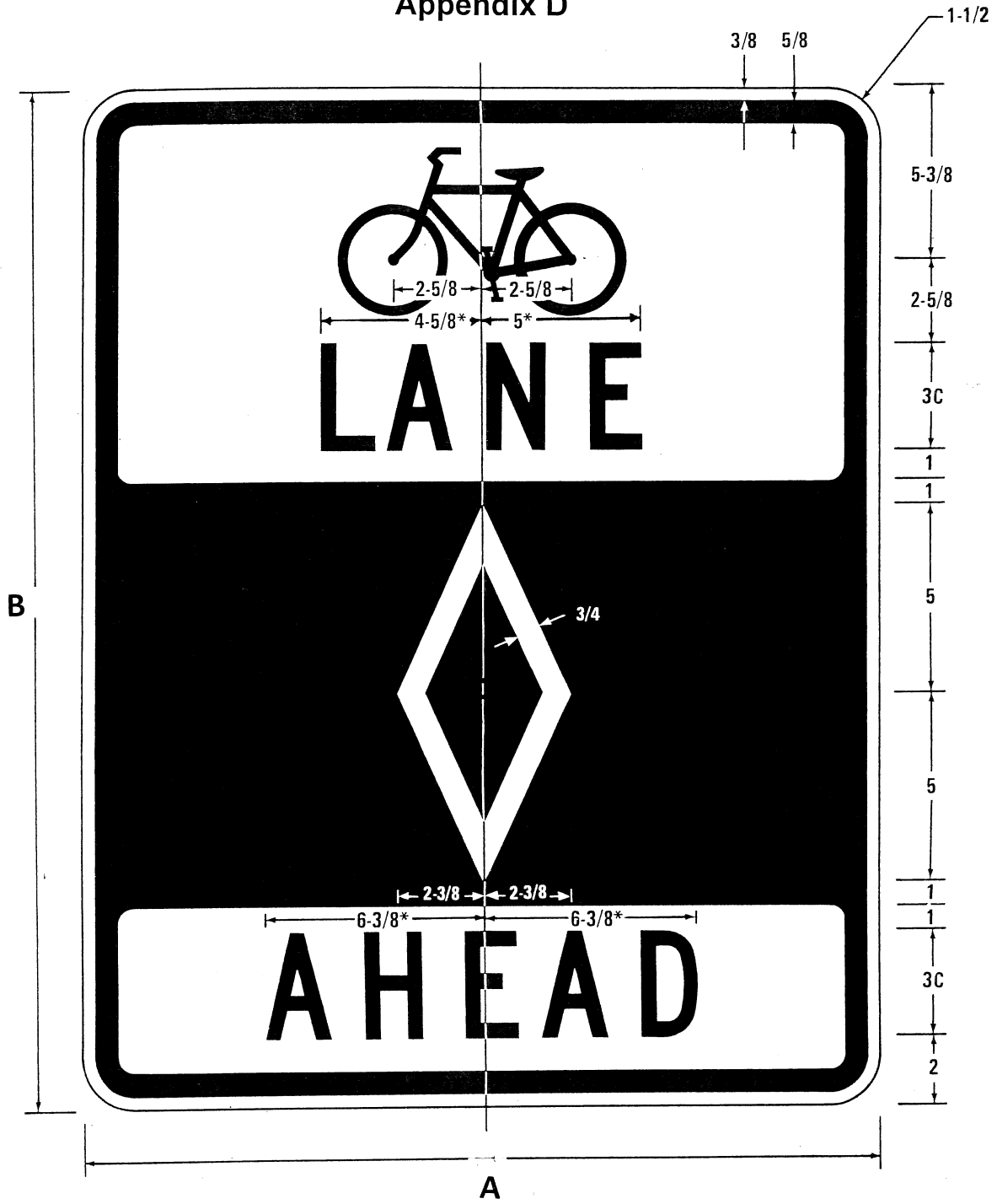

R3-16 NON-STANDARD  
BICYCLE (SYMBOL) LANE AHEAD

C = 3/8"

A	B
24"	30"

COLORS	LEGEND:	BLACK
	BACKGROUND:	WHITE (HIGH INTENSITY PRISMATIC)

Appendix D1

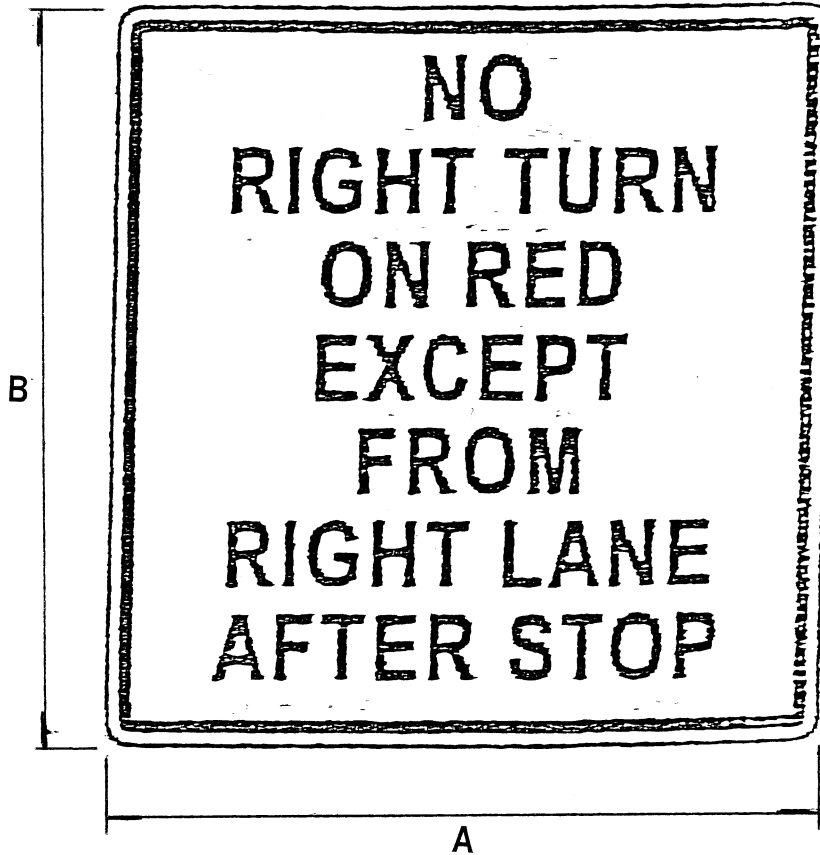

R10-11C (MODIFIED, MUTCD) NON- STANDARD  
NO RIGHT TURN ON RED EXCEPT FROM RIGHT LANE AFTER STOP

A
36"

COLORS	LEGEND:	BLACK
	BACKGROUND:	WHITE (HIGH INTENSITY PRISMATIC)

Appendix E

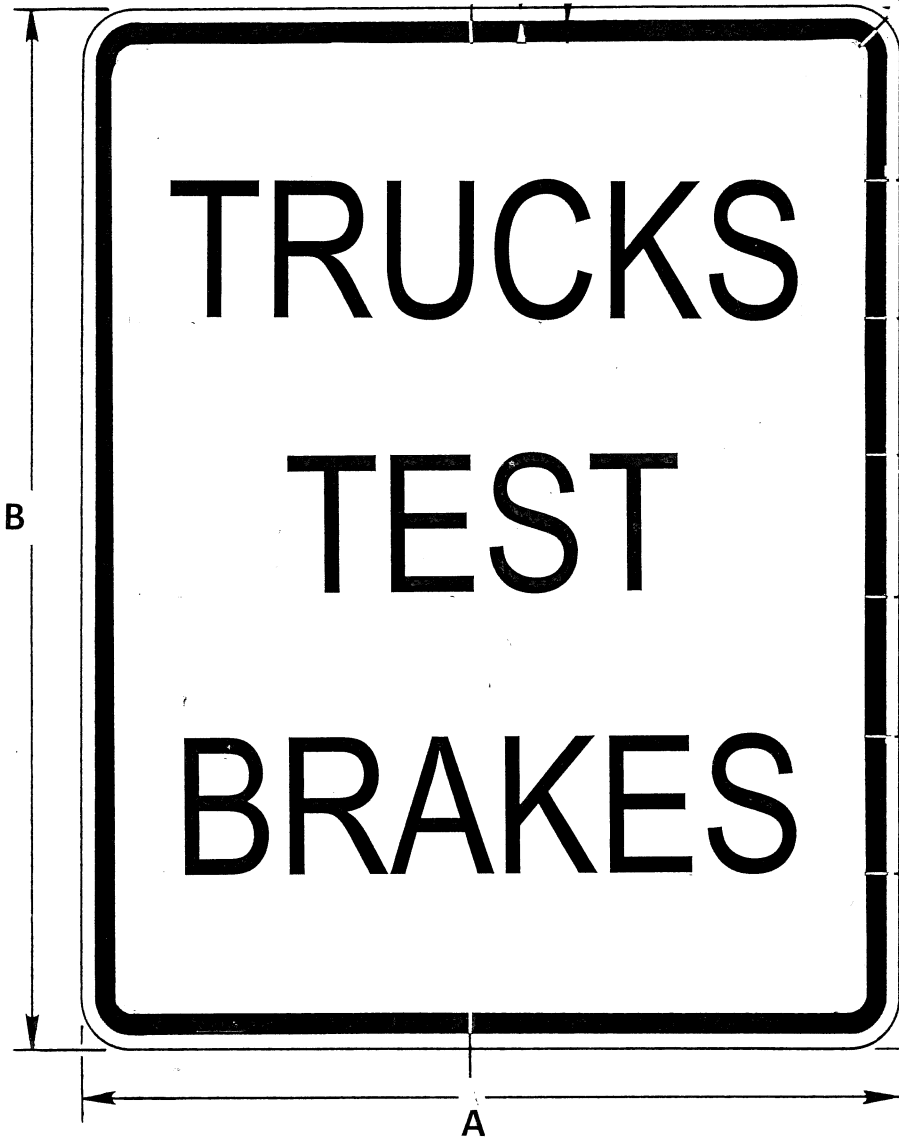

NON- STANDARD  
TRUCKS TEST BRAKES

A	B
36"	42"

COLORS	LEGEND:	BLACK
	BACKGROUND:	WHITE (HIGH INTENSITY PRISMATIC)

# Appendix E1

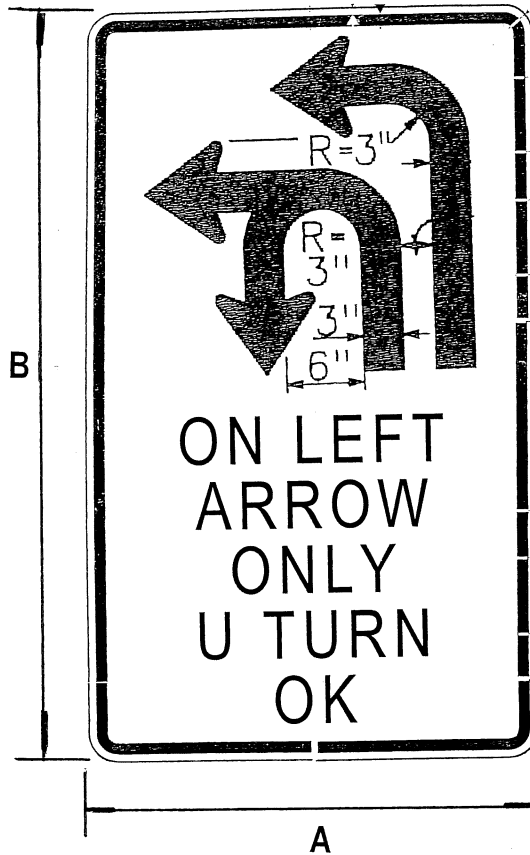

R17-2 (MODIFIED, STANDARD PLANS) NON- STANDARD  
ON LEFT ARROW ONLY U TURN OK

A	B
30"	48"

COLORS	LEGEND:	BLACK
	BACKGROUND:	WHITE (HIGH INTENSITY PRISMATIC)

## Appendix E2

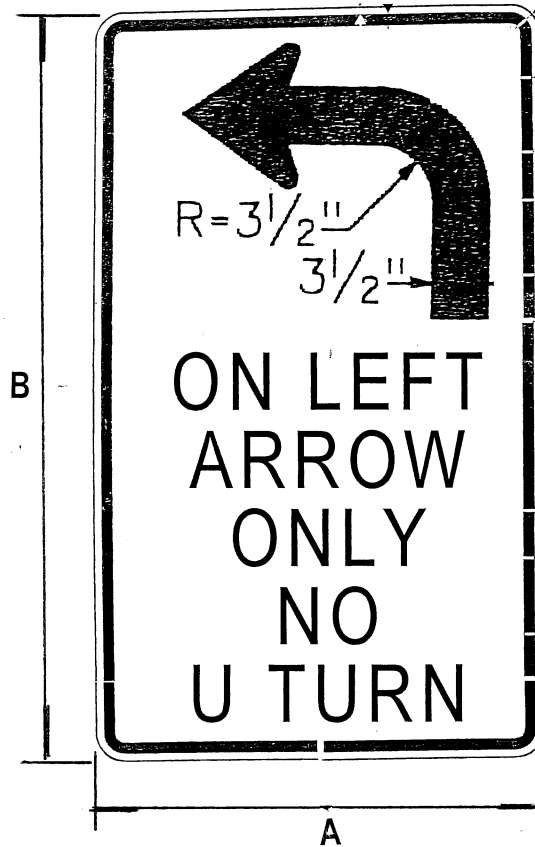

R17-3 (MODIFIED, STANDARD PLANS) NON- STANDARD  
ON LEFT ARROW ONLY NO U TURN

A	B
30"	48"

COLORS	LEGEND:	BLACK
	BACKGROUND:	WHITE (HIGH INTENSITY PRISMATIC)

# Appendix E3

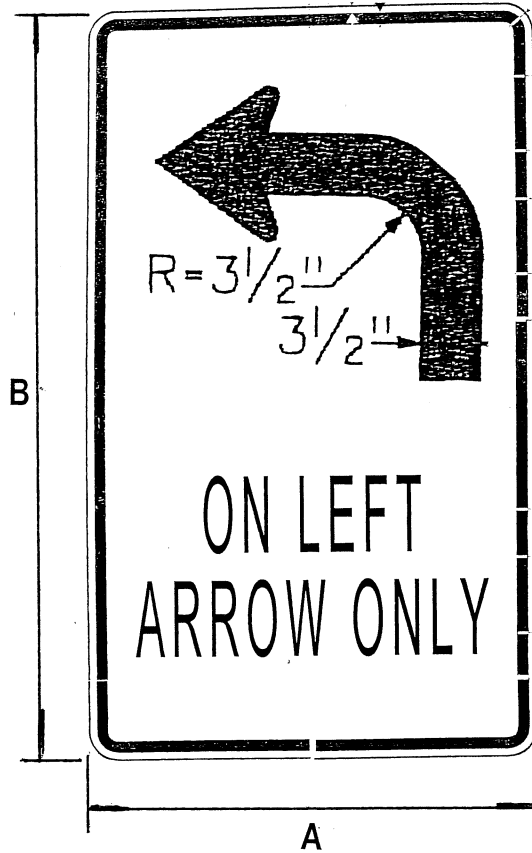

R17-3 NON-STANDARD  
(MODIFIED, STANDARD PLANS)  
ON LEFT ARROW ONLY

A	B
30"	48"

COLORS	LEGEND:	BLACK
	BACKGROUND:	WHITE (HIGH INTENSITY PRISMATIC)

# Appendix E4

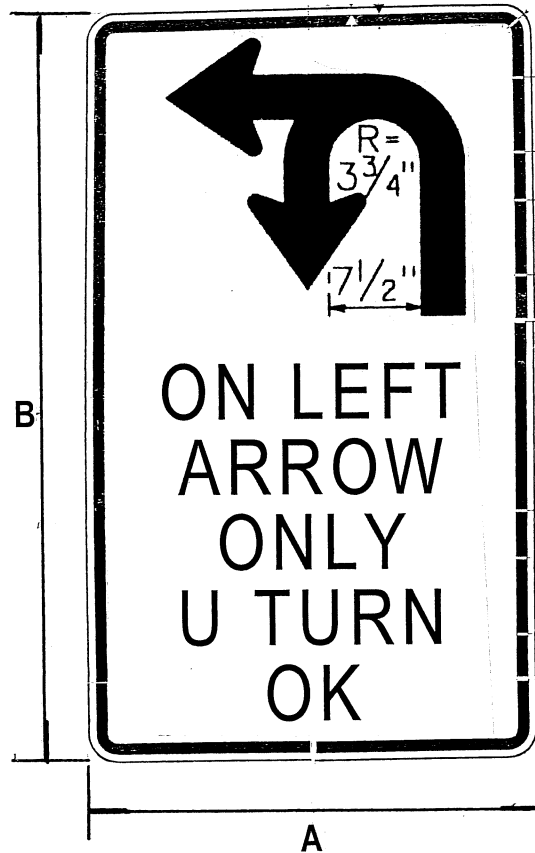

R17-3L NON-STANDARD  
 (MODIFIED, STANDARD PLANS)  
 ON LEFT ARROW ONLY U TURN OK

A	B
30"	48"

COLORS	LEGEND:	BLACK
	BACKGROUND:	WHITE (HIGH INTENSITY PRISMATIC)

# Appendix F

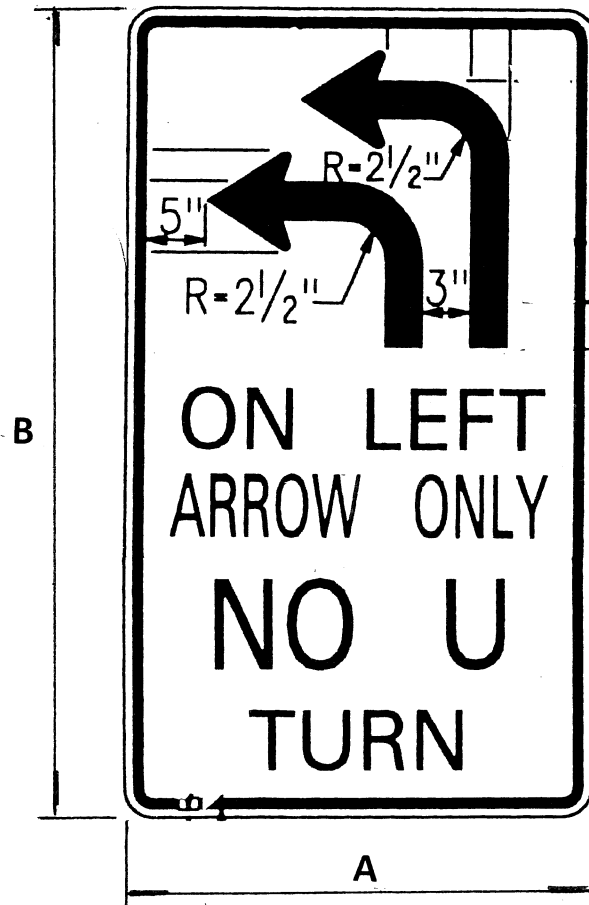

R17-4 NON-STANDARD  
 (MODIFIED, STANDARD PLANS)  
 ON LEFT ARROW ONLY NO U TURN

A	B
30"	48"

COLORS	LEGEND:	BLACK
	BACKGROUND:	WHITE (HIGH INTENSITY PRISMATIC)



# Appendix G

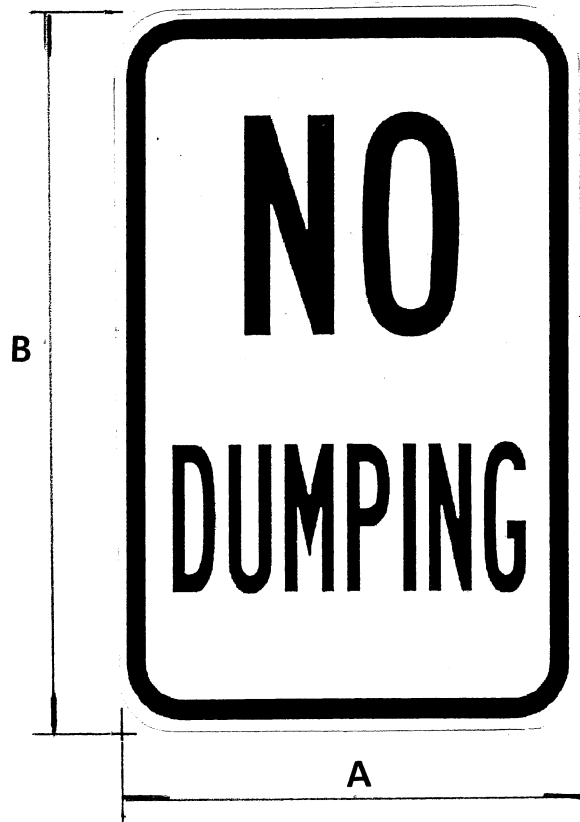

NON- STANDARD  
NO DUMPING

A	B
24"	30"

COLORS	LEGEND:	BLACK
	BACKGROUND:	WHITE (HIGH INTENSITY PRISMATIC)

Appendix G1



NON-STANDARD  
NO JUMPING FROM BRIDGE

A	B
24"	30"

COLORS	LEGEND:	RED
	BACKGROUND:	WHITE (HIGH INTENSITY PRISMATIC)

Appendix G2



NON- STANDARD  
NO VENDING

A	B
24"	30"

COLORS	LEGEND:	RED
	BACKGROUND:	WHITE (HIGH INTENSITY PRISMATIC)

G2-1

Appendix G3

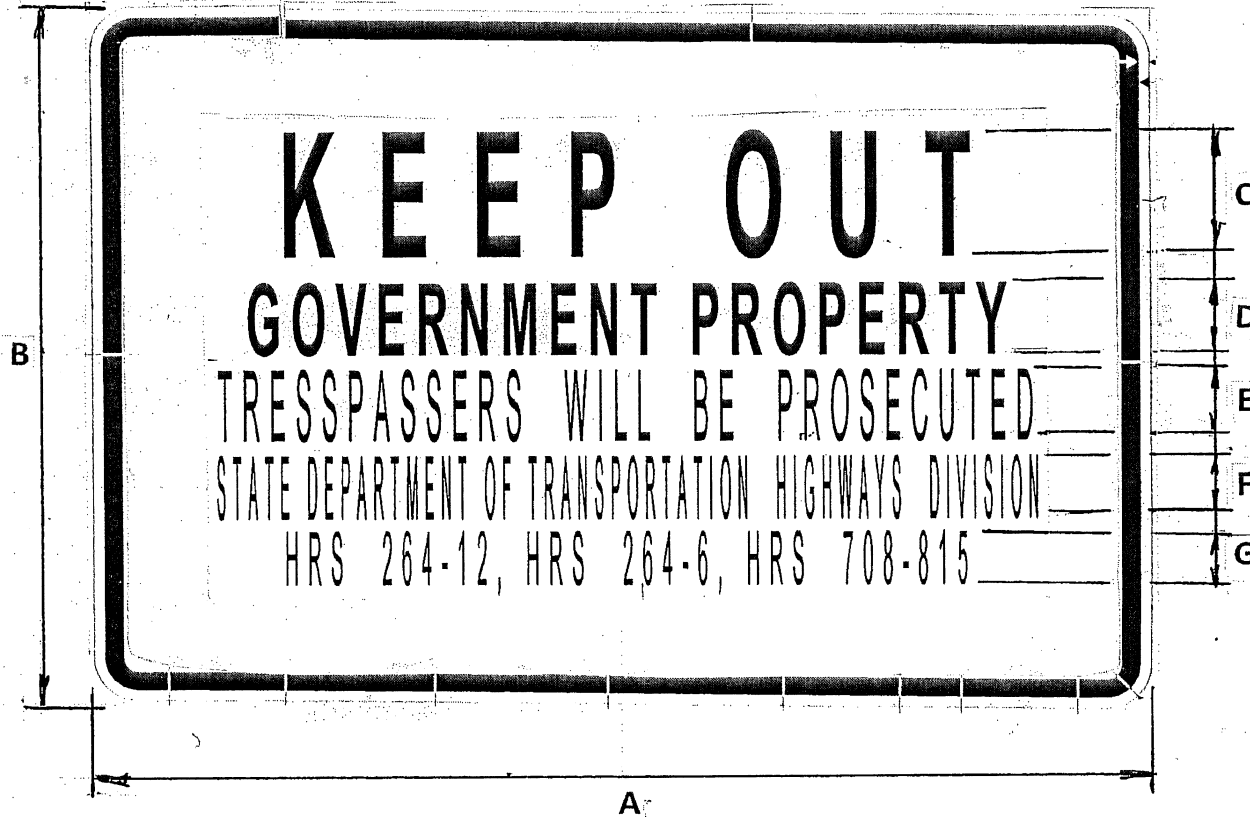

NON-STANDARD

KEEP OUT GOVERNMENT PROPERTY TRESPASSERS WILL BE PROSECUTED  
 STATE DEPARTMENT OF TRANSPORTATION HIGHWAYS DIVISION  
 HRS 264-12, HRS 264-6, HRS 708-815

A	B	C	D	E	F	G
48"	24"	5"	3"	2"	1"	3/4"

COLORS	LEGEND:	WHITE
	BACKGROUND:	BLUE (HIGH INTENSITY PRISMATIC)

Appendix H

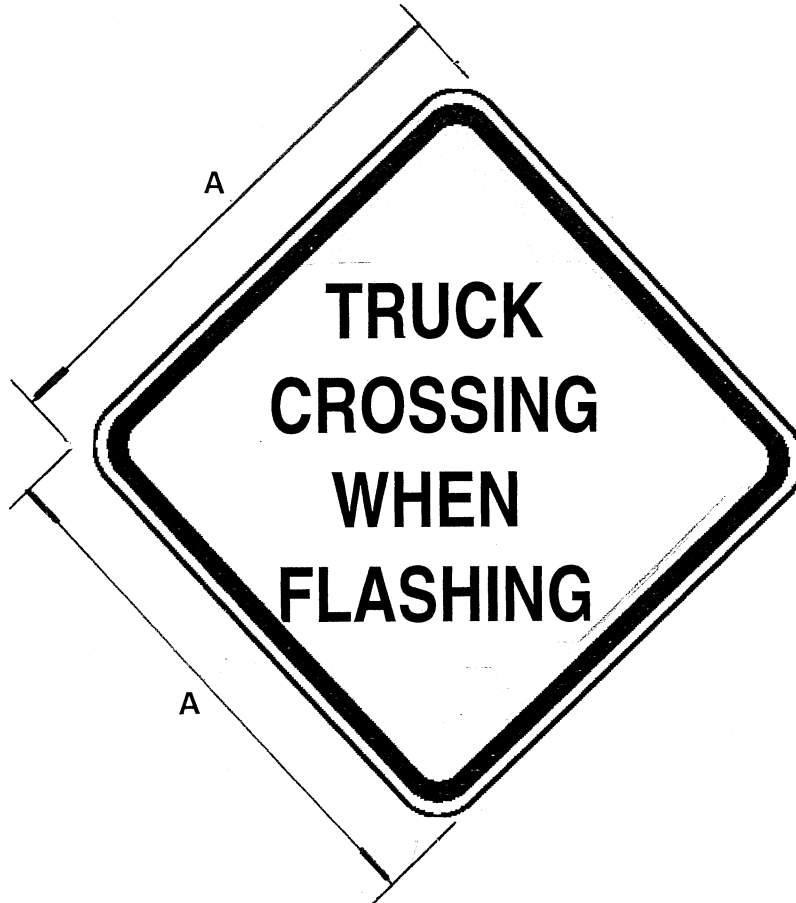

W8-6 NON- STANDARD  
(MODIFIED, MUTCD)  
TRUCK CROSSING WHEN FLASHING

A
48"

COLORS	LEGEND:	BLACK
	BACKGROUND:	YELLOW (HIGH INTENSITY PRISMATIC)

Appendix I

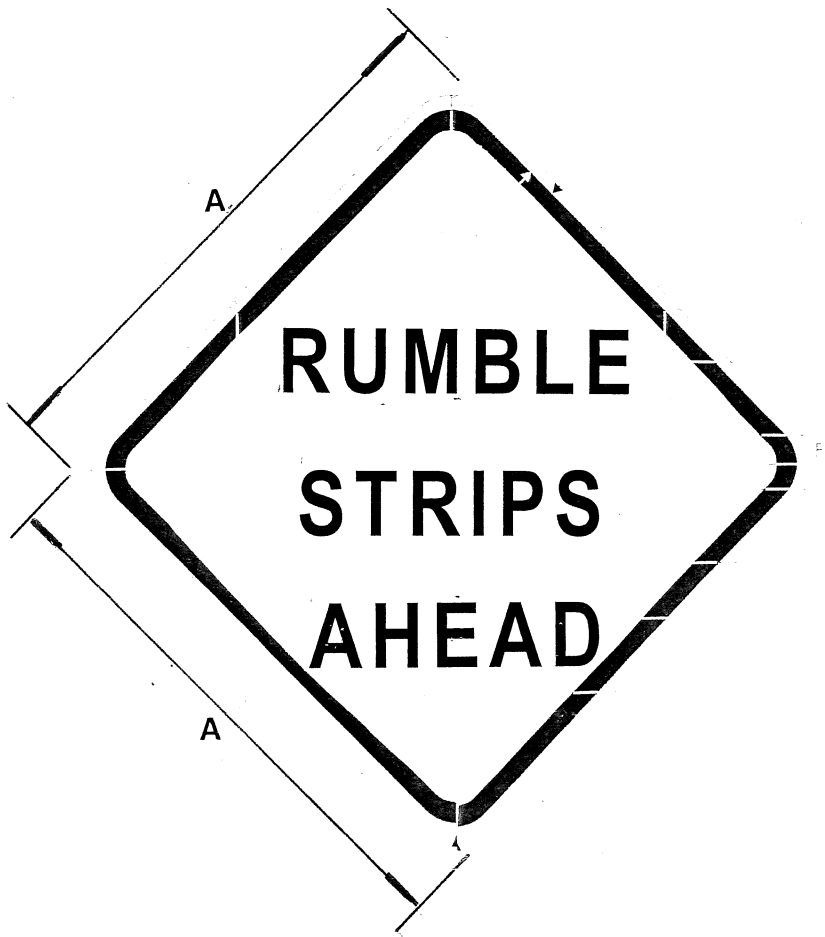

NON- STANDARD  
RUMBLE STRIPS AHEAD

A
36"

COLORS	LEGEND:	BLACK
	BACKGROUND:	YELLOW (HIGH INTENSITY PRISMATIC)

# Appendix I1

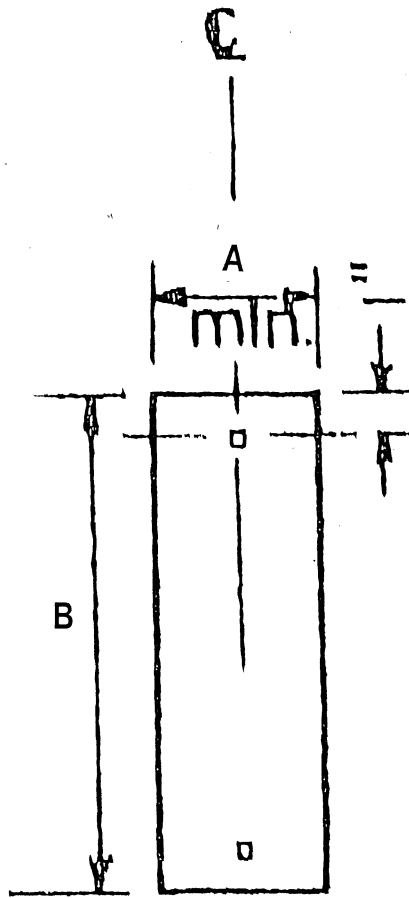

RM-3 NON- STANDARD  
CLEARANCE MARKER

A	B
3"	12"

COLORS	YELLOW (HIGH INTENSITY)
	0.063" THICK ALUMINUM W/ 2-3/8" BOLT HOLE

## Appendix J

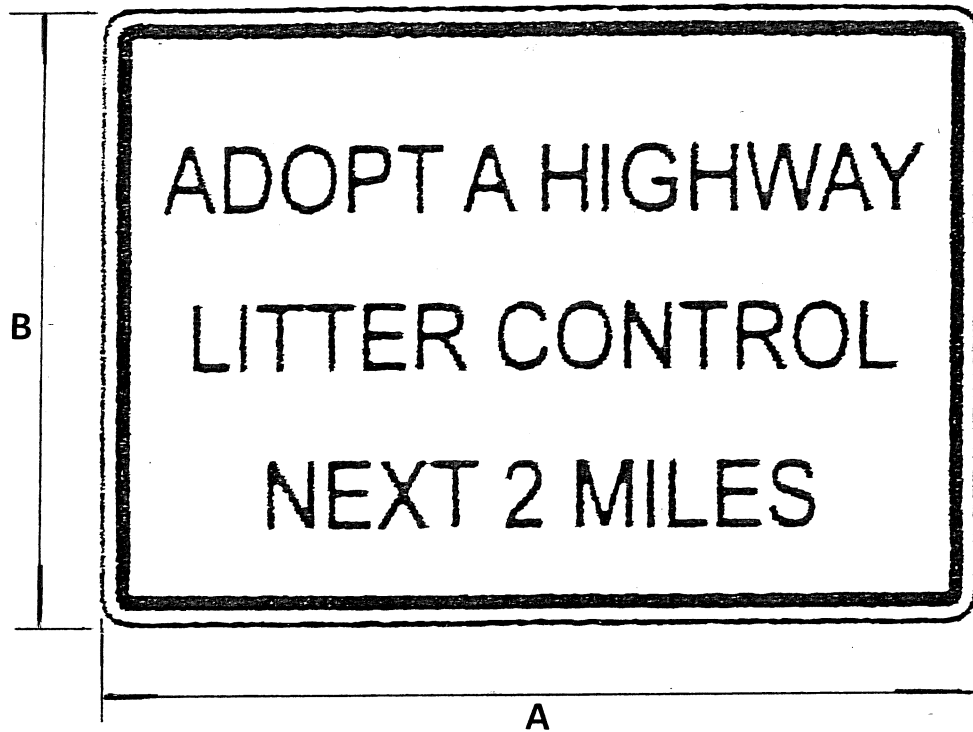

D14-3 NON- STANDARD  
(MODIFIED, MUTCD)  
ADOPT A HIGHWAY LITTER CONTROL NEXT 2 MILES

A	B
48"	24"

COLORS	LEGEND:	BLUE
	BACKGROUND:	WHITE (HIGH INTENSITY PRISMATIC)

Height of lettering shall be 4".



Appendix K

**Ahupua'a Sign**

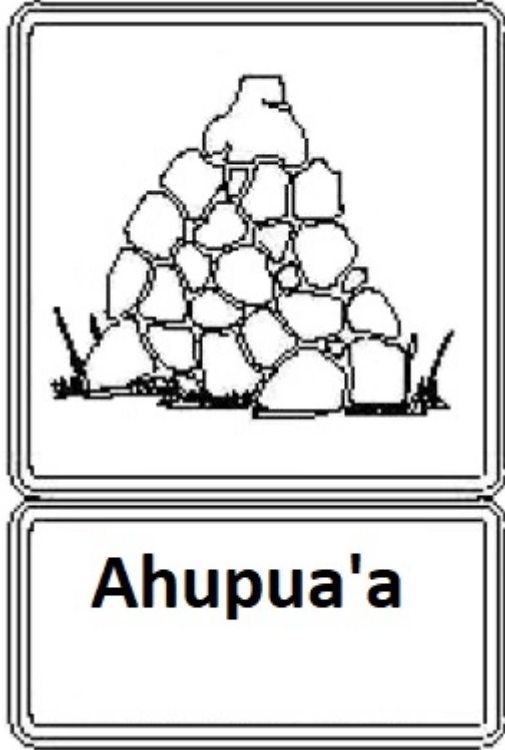

RS-142a  
Ahupua'a  
24"×24"  
Dimond Grade Sheeting  
Brown with white letters and borders  
(modified, MUTCD)

Educational Plaque  
Ahupua'a (blank)  
24"×12"  
Dimond Grade Sheeting  
Brown with white letters and borders  
\*Incidental to RS-142a sign above

**WATCH FOR PEDESTRIANS SIGN (WORDS)**



W15-4  
36"×36"  
Fluorescent Lime-Green Diamond Grade Pedestrian Sign  
(modified, MUTCD)

Appendix M

**SCHOOL XING SIGN (WORDS)**



S2-1P

24"×18"

Fluorescent Lime-Green Diamond Grade Pedestrian Sign  
(modified, MUTCD)

Appendix N

**STOP AHEAD (WORDS)**



W3-1P  
24"×18"  
Yellow Diamond Grade Pedestrian Warning Sign  
(modified, MUTCD)

## Appendix O

### SECTION 750 – TRAFFIC CONTROL SIGN AND MARKER MATERIALS

Make the following amendments to said Section:

(I) Amend **Subsection 750.01(A)(1) Retroreflectorization** by replacing lines 8 through 31 to read:

“(1) **Retroreflectorization.** The following shall be retroreflectorized:

(a) Background for illuminated guide signs and exit number panels ("E" designation) with ASTM D 4956 Type XI retroreflective sheeting.

(b) Background for non-illuminated guide signs and exit number panels ("D" designation) with ASTM D 4956 Type XI retroreflective sheeting.

(c) Messages, arrows, and borders of guide signs and exit number panels ("D" and "E" designations) with ASTM D 4956 Type XI retroreflective sheeting.

(d) Regulatory and warning signs, directional signs ("DIR" designation), route and auxiliary markers, shield symbols, yellow "EXIT ONLY" panels, construction warning signs, and barricade rails, completely, with Type III, IV, or IX retroreflective sheeting.

(e) Pedestrian, school, bicycle crossing series, completely with Type IX fluorescent yellow green retroreflective sheeting.”

(II) Amend **Subsection 750.01(B) Backing** by replacing lines 72 through 73 to read:

“Aluminum sheet shall conform to ASTM B 209, alloy 5052-H38 or 6061-T6 flat sheet.”

(III) Amend **Subsection 750.01(E) Retroreflective Sheeting Materials** by replacing lines 1126 through 1137 to read:

“(E) **Retroreflective Sheeting Materials.** Retroreflective sheeting includes white or colored sheeting having smooth outer surface.

Retroreflective sheeting shall be classified in accordance with ASTM D 4956.

The coefficient of retroreflection shall meet the minimum requirements of ASTM D 4956 for the type of reflective sheeting specified.

## Appendix O

47           The color shall conform to the latest appropriate standard color tolerance  
48 chart issued by the U.S. Department of Transportation, Federal Highway  
49 Administration and to the daytime and nighttime color requirements of ASTM D  
50 4956.

51

52           Test methods and procedures shall be in accordance with ASTM.

53

54 **(IV)** Amend **Subsection 750.02 Sign Posts** by replacing lines 1168 through  
55 1172 to read:

56

57 **"750.02 Square Tube Posts.** Square and other tube posts shall conform to  
58 ASTM A 653 for cold-rolled, carbon steel sheet, commercial quality; or ASTM A  
59 787 for electric-resistance-welded, metallic-coated carbon steel mechanical  
60 tubing."

61

62

63

64

65

66

**END OF SECTION 750**

67

68

69

70

71

Appendix P

Sample – Monthly Invoice

Traffic Signs Supply Co.

1234 Any Street, Honolulu, Hawaii 12345 Phone (808) 123-1234 Fax (808)-123-1234 Email: name@email.com

Bill To: District Engineer – Oahu District
Highways
Department of Transportation
727 Kakoi Street
Honolulu, Hawaii 96819

Date:
Invoice No.:
Contract No.:
Purchase Order No.:
Project No.: HWY-C-09-23

Project Title: Furnishing and Delivering Traffic Signs, Islands of Oahu, Hawaii, Maui and Kauai

Periods Covered: January 17, 2023 to February 16, 2023 (full pay period, head-to-tail format, first pay period from the NTP date to following month similar to this sample)

Table with 6 columns: Bid Item No., Description, Qty, Unit, Unit Price, Amount. Rows include items 1, 2, 27, 220, Subtotal, Less Deductions, and Total Amount Due.

I certify that services requested under the contract have been performed by Traffic Signs Supply Co. in accordance with the contract.

Signature
First J. Name
President
Traffic Signs Supply Co.

**APPENDIX Q**  
**Sample - Satisfactory Evidence by Affidavit for Final Payment**

**Traffic Control Services**

1234 Any Street, Honolulu, Hawaii 12345    Phone: (808) 123-1235    Email: name@email.com

Date:

State of Hawaii  
Department of Transportation  
869 Punchbowl Street  
Honolulu, Hawaii 96813-5097

Dear Sir/Madam:

Pursuant to Section 9.5.B Final Payment, of the Specifications, I hereby certify that all debts resulting from Contract No. \_\_\_\_\_, Project No. HWY-C-09-23, Project Title: Furnishing and Delivering Traffic Signs, Island of Oahu, Hawaii, Maui and Kauai, have been fully paid or satisfactorily secured.

Cordially,

\_\_\_\_\_  
First J. Name  
President  
Traffic Control Services

Subscribed and sworn to me  
this \_\_\_\_\_ day of \_\_\_\_\_, 20\_\_\_\_\_.

\_\_\_\_\_  
Notary Public, First Judicial Circuit,  
State of Hawaii

My Commission Expires: \_\_\_\_\_





The bidder shall refer to Section 10.6(D) Schedule of Submitting Required Documents and be familiar with the requirements prior to submitting their bids. The bidder, **starting with the lowest bidder**, is required to submit specific documents.

**Failure by the bidder to submit.** The bidder maybe considered non-compliant with the requirements of the Special Provisions and the Specifications if the bidder fails to submit the documents to the Project Manager no later than **seven (7) working days** from the date of receipt of the written request from the State. This failure may result in bid rejection by the Department of Transportation.

STATE OF HAWAII  
DEPARTMENT OF TRANSPORTATION  
HIGHWAYS  
HONOLULU, HAWAII

PROPOSAL

PROPOSAL TO THE STATE OF HAWAII  
DEPARTMENT OF TRANSPORTATION  
HIGHWAYS

PROJECT: FURNISHING AND DELIVERING TRAFFIC SIGNS,  
ISLANDS OF OAHU, HAWAII, MAUI AND KAUAI

PROJECT NO.: HWY-C-09-23

CONTRACT TIME: Twelve (12) months from date indicated in the Notice to Proceed from the Department with options to extend as provided for in Section 10.8, of the Specifications.

LIQUIDATED DAMAGES: Refer to Section 8.6 Liquidated Damage, of the Special Provisions and Section 10.10 Basis For Payment, of the Specification for applicable deductions.

PROJECT MANAGER CONTACT INFORMATION: Jake Dickman  
869 Punchbowl Street, Room 404, Honolulu, HI 96813  
(808) 587-2189  
jake.j.dickman@hawaii.gov

ELECTRONIC SUBMITTAL: **Bidders shall submit and upload the complete proposal to HiePRO prior to the bid opening date and time. Any additional support documents explicitly designated as confidential and/or proprietary shall be uploaded as a separate file to HiePRO. See SPECIAL PROVISIONS 2.3 DELIVERY OF PROPOSALS for complete details. FAILURE TO UPLOAD THE COMPLETE PROPOSAL TO HiePRO SHALL BE GROUNDS FOR REJECTION OF THE BID.**

NOTE: **BID, PERFORMANCE AND PAYMENT BONDS ARE NOT REQUIRED FOR THIS PROJECT.**

Director of Transportation  
Aliiainmoku Hale  
869 Punchbowl Street  
Honolulu, Hawaii 96813

Dear Sir:

The undersigned bidder declares the following:

1. It has not, either directly or indirectly, entered into any agreement, participated in any collusion, or otherwise taken any action in restraint of free competitive bidding in connection with this proposal.
2. It has not been assisted or represented on this matter by any individual who has, in a State capacity, been involved in the subject matter of this contract within the past two years.
3. It has not and will not, either directly or indirectly offered or given a gratuity (i.e. an entertainment or gift) to any State or County employee to obtain a contract or favorable treatment under a contract.

The undersigned bidder further agrees to the following:

1. If this proposal is accepted, it shall execute a contract with the Department to provide all necessary labor, machinery, tools, equipment, apparatus and any other means of construction, to do all the work and to furnish all the materials specified in the contract in the manner and within the time therein prescribed in the contract, and that it shall accept in full payment therefore the sum of the unit and/or lump sum prices as set forth in the attached proposal schedule for the actual quantities of work performed and materials furnished and furnish satisfactory security in accordance with Section 103D-324, Hawaii Revised Statutes, within 10 days after the award of the contract or within such time as the Director of Transportation may allow after the undersigned has received the contract documents for execution, and is fully aware that non-compliance with the aforementioned terms will result in the forfeiture of the full amount of the bid guarantee required under Section 103D-323, Hawaii Revised Statutes.

Matls. & Serv.  
r12/2020

2. That the quantities given in the attached proposal schedule are approximate only and are intended principally to serve as a guide in determining and comparing the bids.
3. That the Department does not either expressly or by implication, agree that the actual amount of work will correspond therewith, but reserves the right to increase or decrease the amount of any class or portion of the work, or to omit portions of the work, as may be deemed necessary or advisable by the Director of Transportation, and that all increased or decreased quantities of work shall be performed at the unit prices set forth in the attached proposal schedule except as provided for in the specifications.
4. In case of a discrepancy between unit prices and the totals in said Proposal Schedule, the unit prices shall prevail.
5. Agrees to begin work within 10 working days after the date of notification to commence with the work, which date is in the notice to proceed, and shall finish the entire project within the time prescribed.
6. The Director of Transportation reserves the right to reject any or all bids and to waive any defects when in the Director's opinion such rejections or waiver will be for the best interest of the public.

Receipt is hereby acknowledged and complete examination is hereby expressly guaranteed of the following listed items: the specifications, the notice to bidders, the special provisions, if any, the proposal, the plans, if any, and the contract form.

The undersigned acknowledges receipt of any addendum, issued by recording in the space below the date of receipt.

Addendum No. 1 \_\_\_\_\_ Addendum No. 3 \_\_\_\_\_

Addendum No. 2 \_\_\_\_\_ Addendum No. 4 \_\_\_\_\_

The undersigned hereby certifies that the bid prices contained in the attached proposal schedule have been carefully checked and are submitted as correct, final and are net prices.

\_\_\_\_\_  
Bidder (Company Name)

By \_\_\_\_\_  
Authorized Signature

\_\_\_\_\_  
Print Name and Title

\_\_\_\_\_  
Business Address

\_\_\_\_\_  
Business Telephone      Email

\_\_\_\_\_  
Date

\_\_\_\_\_  
Contact Person (If different from above)

Phone: \_\_\_\_\_ Email: \_\_\_\_\_

\*Hawaii General Excise Tax License No. \_\_\_\_\_

NOTE:

If bidder is a CORPORATION, the legal name of the corporation shall be set forth above, the corporate seal affixed, together with the signature(s) of the officer(s) authorized to sign contracts on behalf of the corporation. Please attach to this page current (not more than six months old) evidence of the authority of the officer(s) to sign on behalf of the corporation.

If bidder is a PARTNERSHIP, the true name of the partnership shall be set forth above with the signature(s) of the general partner(s) authorized to sign contracts on behalf of the partnership. Please attach to this page current (not more than six months old) evidence of the authority of the partner(s) to sign on behalf of the partnership.

If bidder is an INDIVIDUAL, the bidder's signature shall be placed in the space provided therefore on page PF-4.

If signature is by an agent, other than an officer of a corporation or a partner of a partnership, a POWER OF ATTORNEY must be on file with the Department prior to the opening of bids or submitted with the bid; otherwise, the bid may be rejected as irregular and unauthorized.

\*Bidder will be considered an out-of-state vendor if Hawaii General Excise Tax License No. is not indicated. See Section 2.8 Out-of-State Bidders of the Specifications.

FURNISHING AND DELIVERING TRAFFIC SIGNS  
PROJECT NO. HWY-C-09-23  
ISLANDS OF OAHU, HAWAII, MAUI AND KAUAI  
**PROPOSAL SCHEDULE**

**1. SIGNS, REGULATORY (REFLECTORIZED, HIGH INTENSITY PRISMATIC):**

BID ITEM NO.	ITEM	OAHU DISTRICT			HAWAII DISTRICT			MAUI DISTRICT			KAUAI DISTRICT		
		EST. YEARLY QTY. (EACH) (A)	UNIT PRICE (B)	AMOUNT (A x B)	EST. YEARLY QTY. (EACH) (C)	UNIT PRICE (D)	AMOUNT (C x D)	EST. YEARLY QTY. (EACH) (E)	UNIT PRICE (F)	AMOUNT (E x F)	EST. YEARLY QTY. (EACH) (G)	UNIT PRICE (H)	AMOUNT (G x H)
1	30" x 30", R1-1 STOP	200	\$ _____	\$ _____	60	\$ _____	\$ _____	150	\$ _____	\$ _____	200	\$ _____	\$ _____
2	36" x 36", R1-1-A (Standard Plan) STOP	10	\$ _____	\$ _____	24	\$ _____	\$ _____	0	\$ 0.00	\$ 0.00	0	\$ 0.00	\$ 0.00
3	36" x 36", R1-2 YIELD	5	\$ _____	\$ _____	36	\$ _____	\$ _____	75	\$ _____	\$ _____	5	\$ _____	\$ _____
4	18" x 6", R1-4 ALL WAY	25	\$ _____	\$ _____	0	\$ 0.00	\$ 0.00	0	\$ 0.00	\$ 0.00	0	\$ 0.00	\$ 0.00
5	30" x 36", R1-5c STOP HERE FOR PEDESTRIANS (words & arrow)	50	\$ _____	\$ _____	0	\$ 0.00	\$ 0.00	0	\$ 0.00	\$ 0.00	10	\$ _____	\$ _____
6	24" x 30", Non-standard, UNLAWFUL TO LITTER \$1000 FINE (words) <i>Refer to Appendix B</i>	100	\$ _____	\$ _____	0	\$ 0.00	\$ 0.00	0	\$ 0.00	\$ 0.00	5	\$ _____	\$ _____
6a	R1-6a In-street Pedestrian Crosswalk Sign, Surface Mount, Fixed or Quick Release Model, Double Sided, Text on both sides to read "STATE LAW STOP FOR (Ped Symbol) WITHIN CROSSWALK (MUTCD) (Fluorescent lime-green)	0	\$ 0.00	\$ 0.00	0	\$ 0.00	\$ 0.00	20	\$ _____	\$ _____	10	\$ _____	\$ _____
7	24" x 18", Non-standard, NO CAMPING (words) <i>Refer to Appendix C</i>	30	\$ _____	\$ _____	0	\$ 0.00	\$ 0.00	0	\$ 0.00	\$ 0.00	0	\$ 0.00	\$ 0.00
8	24" x 30", R2-1 (25) SPEED LIMIT 25	100	\$ _____	\$ _____	0	\$ 0.00	\$ 0.00	0	\$ 0.00	\$ 0.00	15	\$ _____	\$ _____
9	24" x 30", R2-1 ( ) SPEED LIMIT blank	200	\$ _____	\$ _____	20	\$ _____	\$ _____	50	\$ _____	\$ _____	30	\$ _____	\$ _____
10	24" x 30", R2-1 (35) SPEED LIMIT 35	200	\$ _____	\$ _____	0	\$ 0.00	\$ 0.00	0	\$ 0.00	\$ 0.00	15	\$ _____	\$ _____



FURNISHING AND DELIVERING TRAFFIC SIGNS  
PROJECT NO. HWY-C-09-23  
ISLANDS OF OAHU, HAWAII, MAUI AND KAUAI  
**PROPOSAL SCHEDULE**

**1. SIGNS, REGULATORY (REFLECTORIZED, HIGH INTENSITY PRISMATIC) (CONTINUATION):**

BID ITEM NO.	ITEM	OAHU DISTRICT			HAWAII DISTRICT			MAUI DISTRICT			KAUAI DISTRICT		
		EST. YEARLY QTY. (EACH) (A)	UNIT PRICE (B)	AMOUNT (A x B)	EST. YEARLY QTY. (EACH) (C)	UNIT PRICE (D)	AMOUNT (C x D)	EST. YEARLY QTY. (EACH) (E)	UNIT PRICE (F)	AMOUNT (E x F)	EST. YEARLY QTY. (EACH) (G)	UNIT PRICE (H)	AMOUNT (G x H)
11	36" x 48", R2-1 ( ) – B (Standard Plan) SPEED LIMIT blank	100	\$ _____	\$ _____	20	\$ _____	\$ _____	25	\$ _____	\$ _____	30	\$ _____	\$ _____
12	36" x 48", R2-1 (25) – B (Standard Plan) SPEED LIMIT 25	25	\$ _____	\$ _____	12	\$ _____	\$ _____	0	\$ 0.00	\$ 0.00	5	\$ _____	\$ _____
13	36" x 48", R2-1 (35) – B (Standard Plan) SPEED LIMIT 35	100	\$ _____	\$ _____	12	\$ _____	\$ _____	0	\$ 0.00	\$ 0.00	5	\$ _____	\$ _____
14	36" x 48", R2-1 (45) – B (Standard Plan) SPEED LIMIT 45	50	\$ _____	\$ _____	12	\$ _____	\$ _____	0	\$ 0.00	\$ 0.00	5	\$ _____	\$ _____
15	48" x 60", R2-1 ( ) – A (Standard Plan) SPEED LIMIT blank	50	\$ _____	\$ _____	0	\$ 0.00	\$ 0.00	0	\$ 0.00	\$ 0.00	0	\$ 0.00	\$ 0.00
16	48" x 60", R2-1 (45) SPEED LIMIT 45	50	\$ _____	\$ _____	0	\$ 0.00	\$ 0.00	0	\$ 0.00	\$ 0.00	0	\$ 0.00	\$ 0.00
17	36" x 48", R2-1 (50) SPEED LIMIT 50	25	\$ _____	\$ _____	0	\$ 0.00	\$ 0.00	0	\$ 0.00	\$ 0.00	5	\$ _____	\$ _____
18	36" x 48", R2-1 (55) SPEED LIMIT 55	5	\$ _____	\$ _____	12	\$ _____	\$ _____	0	\$ 0.00	\$ 0.00	0	\$ 0.00	\$ 0.00
19	48" x 60", R2-1 (55) SPEED LIMIT 55	50	\$ _____	\$ _____	0	\$ 0.00	\$ 0.00	0	\$ 0.00	\$ 0.00	0	\$ 0.00	\$ 0.00

FURNISHING AND DELIVERING TRAFFIC SIGNS  
PROJECT NO. HWY-C-09-23  
ISLANDS OF OAHU, HAWAII, MAUI AND KAUAI  
**PROPOSAL SCHEDULE**

**1. SIGNS, REGULATORY (REFLECTORIZED, HIGH INTENSITY PRISMATIC) (CONTINUATION):**

BID ITEM NO.	ITEM	OAHU DISTRICT			HAWAII DISTRICT			MAUI DISTRICT			KAUAI DISTRICT		
		EST. YEARLY QTY. (EACH) (A)	UNIT PRICE (B)	AMOUNT (A x B)	EST. YEARLY QTY. (EACH) (C)	UNIT PRICE (D)	AMOUNT (C x D)	EST. YEARLY QTY. (EACH) (E)	UNIT PRICE (F)	AMOUNT (E x F)	EST. YEARLY QTY. (EACH) (G)	UNIT PRICE (H)	AMOUNT (G x H)
20	48" x 60", R2-1 (60) SPEED LIMIT 60	25	\$ _____	\$ _____	0	\$ 0.00	\$ 0.00	0	\$ 0.00	\$ 0.00	0	\$ 0.00	\$ 0.00
21	24" x 48", R2-4a (55/45) (MUTCD) COMBINED SPEED LIMIT 55/45	10	\$ _____	\$ _____	0	\$ 0.00	\$ 0.00	0	\$ 0.00	\$ 0.00	0	\$ 0.00	\$ 0.00
22	48" x 96", R2-4a (55/45) – A (MUTCD) COMBINED SPEED LIMIT 55/45	20	\$ _____	\$ _____	0	\$ 0.00	\$ 0.00	0	\$ 0.00	\$ 0.00	0	\$ 0.00	\$ 0.00
23	48" x 96", R2-4a (50/40) – A (MUTCD) COMBINED SPEED LIMIT 50/40	40	\$ _____	\$ _____	0	\$ 0.00	\$ 0.00	0	\$ 0.00	\$ 0.00	0	\$ 0.00	\$ 0.00
24	48" x 96", R2-4a (55/45) – A (MUTCD) COMBINED SPEED LIMIT 55/45	20	\$ _____	\$ _____	0	\$ 0.00	\$ 0.00	0	\$ 0.00	\$ 0.00	0	\$ 0.00	\$ 0.00

FURNISHING AND DELIVERING TRAFFIC SIGNS  
PROJECT NO. HWY-C-09-23  
ISLANDS OF OAHU, HAWAII, MAUI AND KAUAI  
**PROPOSAL SCHEDULE**

**1. SIGNS, REGULATORY (REFLECTORIZED, HIGH INTENSITY PRISMATIC) (CONTINUATION):**

BID ITEM NO.	ITEM	OAHU DISTRICT			HAWAII DISTRICT			MAUI DISTRICT			KAUAI DISTRICT		
		EST. YEARLY QTY. (EACH) (A)	UNIT PRICE (B)	AMOUNT (A x B)	EST. YEARLY QTY. (EACH) (C)	UNIT PRICE (D)	AMOUNT (C x D)	EST. YEARLY QTY. (EACH) (E)	UNIT PRICE (F)	AMOUNT (E x F)	EST. YEARLY QTY. (EACH) (G)	UNIT PRICE (H)	AMOUNT (G x H)
25	36" x 36", W3-5 (25), Non-standard, REDUCED SPEED LIMIT AHEAD - 25	50	\$ _____	\$ _____	0	\$ 0.00	\$ 0.00	0	\$ 0.00	\$ 0.00	0	\$ 0.00	\$ 0.00
26	48" x 48", W3-5 (25), Non-standard, REDUCED SPEED LIMIT AHEAD - 25	50	\$ _____	\$ _____	0	\$ 0.00	\$ 0.00	0	\$ 0.00	\$ 0.00	0	\$ 0.00	\$ 0.00
27	36" x 36", W3-5 (35), Non-standard, REDUCED SPEED LIMIT AHEAD - 35	50	\$ _____	\$ _____	0	\$ 0.00	\$ 0.00	0	\$ 0.00	\$ 0.00	5	\$ _____	\$ _____
28	48" x 48", W3-5 (35), Non-standard, REDUCED SPEED LIMIT AHEAD - 35	50	\$ _____	\$ _____	12	\$ _____	\$ _____	0	\$ 0.00	\$ 0.00	0	\$ 0.00	\$ 0.00
29	36" x 36", W3-5 (45), Non-standard, REDUCED SPEED LIMIT AHEAD - 45	50	\$ _____	\$ _____	0	\$ 0.00	\$ 0.00	0	\$ 0.00	\$ 0.00	5	\$ _____	\$ _____
30	48" x 48", W3-5 (45), Non-standard, REDUCED SPEED LIMIT AHEAD - 45	50	\$ _____	\$ _____	0	\$ 0.00	\$ 0.00	0	\$ 0.00	\$ 0.00	5	\$ _____	\$ _____
31	36" x 36", W3-5 ( ), Non-standard, REDUCED SPEED LIMIT AHEAD - (blank)	25	\$ _____	\$ _____	0	\$ 0.00	\$ 0.00	0	\$ 0.00	\$ 0.00	0	\$ 0.00	\$ 0.00
32	48" x 48", W3-5 ( ), Non-standard, REDUCED SPEED LIMIT AHEAD - (blank)	50	\$ _____	\$ _____	0	\$ 0.00	\$ 0.00	0	\$ 0.00	\$ 0.00	0	\$ 0.00	\$ 0.00

FURNISHING AND DELIVERING TRAFFIC SIGNS  
PROJECT NO. HWY-C-09-23  
ISLANDS OF OAHU, HAWAII, MAUI AND KAUAI  
**PROPOSAL SCHEDULE**

**1. SIGNS, REGULATORY (REFLECTORIZED, HIGH INTENSITY PRISMATIC) (CONTINUATION):**

BID ITEM NO.	ITEM	OAHU DISTRICT			HAWAII DISTRICT			MAUI DISTRICT			KAUAI DISTRICT		
		EST. YEARLY QTY. (EACH) (A)	UNIT PRICE (B)	AMOUNT (A x B)	EST. YEARLY QTY. (EACH) (C)	UNIT PRICE (D)	AMOUNT (C x D)	EST. YEARLY QTY. (EACH) (E)	UNIT PRICE (F)	AMOUNT (E x F)	EST. YEARLY QTY. (EACH) (G)	UNIT PRICE (H)	AMOUNT (G x H)
33	24" x 24", R3-1 (MUTCD) NO RIGHT TURN (symbol)	50	\$ _____	\$ _____	12	\$ _____	\$ _____	50	\$ _____	\$ _____	5	\$ _____	\$ _____
34	36" x 36", R3-1 (MUTCD) NO RIGHT TURN (symbol)	15	\$ _____	\$ _____	0	\$ 0.00	\$ 0.00	10	\$ _____	\$ _____	0	\$ 0.00	\$ 0.00
35	48" x 48", R3-1-A (Standard Plan) NO RIGHT TURN (symbol)	15	\$ _____	\$ _____	0	\$ 0.00	\$ 0.00	0	\$ 0.00	\$ 0.00	0	\$ 0.00	\$ 0.00
36	24" x 18", R3-1 plaque (Standard Plan) NO RIGHT TURN (words)	50	\$ _____	\$ _____	12	\$ _____	\$ _____	0	\$ 0.00	\$ 0.00	5	\$ _____	\$ _____
37	48" x 36", R3-1-A plaque (Standard Plan) NO RIGHT TURN (words)	20	\$ _____	\$ _____	0	\$ 0.00	\$ 0.00	0	\$ 0.00	\$ 0.00	0	\$ 0.00	\$ 0.00
38	24" x 24", R3-2 (MUTCD) NO LEFT TURN (symbol)	100	\$ _____	\$ _____	12	\$ _____	\$ _____	50	\$ _____	\$ _____	5	\$ _____	\$ _____
39	36" x 36", R3-2 (MUTCD) NO LEFT TURN (symbol)	15	\$ _____	\$ _____	0	\$ 0.00	\$ 0.00	10	\$ _____	\$ _____	0	\$ 0.00	\$ 0.00
40	48" x 48", R3-2-A (Standard Plan) NO LEFT TURN (symbol)	15	\$ _____	\$ _____	0	\$ 0.00	\$ 0.00	0	\$ 0.00	\$ 0.00	0	\$ 0.00	\$ 0.00
41	24" x 18", R3-2 plaque NO LEFT TURN (words)	50	\$ _____	\$ _____	12	\$ _____	\$ _____	0	\$ 0.00	\$ 0.00	5	\$ _____	\$ _____

FURNISHING AND DELIVERING TRAFFIC SIGNS  
PROJECT NO. HWY-C-09-23  
ISLANDS OF OAHU, HAWAII, MAUI AND KAUAI  
**PROPOSAL SCHEDULE**

**1. SIGNS, REGULATORY (REFLECTORIZED, HIGH INTENSITY PRISMATIC) (CONTINUATION):**

BID ITEM NO.	ITEM	OAHU DISTRICT			HAWAII DISTRICT			MAUI DISTRICT			KAUAI DISTRICT		
		EST. YEARLY QTY. (EACH) (A)	UNIT PRICE (B)	AMOUNT (A x B)	EST. YEARLY QTY. (EACH) (C)	UNIT PRICE (D)	AMOUNT (C x D)	EST. YEARLY QTY. (EACH) (E)	UNIT PRICE (F)	AMOUNT (E x F)	EST. YEARLY QTY. (EACH) (G)	UNIT PRICE (H)	AMOUNT (G x H)
42	48" x 36", R3-2-A plaque (Standard Plan) NO LEFT TURN (words)	20	\$ _____	\$ _____	0	\$ 0.00	\$ 0.00	0	\$ 0.00	\$ 0.00	0	\$ 0.00	\$ 0.00
43	36" x 36", R3-3 (MUTCD) NO TURNS	25	\$ _____	\$ _____	0	\$ 0.00	\$ 0.00	0	\$ 0.00	\$ 0.00	0	\$ 0.00	\$ 0.00
44	24" x 24", R3-3 (MUTCD) NO TURNS	25	\$ _____	\$ _____	0	\$ 0.00	\$ 0.00	0	\$ 0.00	\$ 0.00	5	\$ _____	\$ _____
45	24" x 24", R3-4 (MUTCD) NO U TURN (symbol)	50	\$ _____	\$ _____	12	\$ _____	\$ _____	20	\$ _____	\$ _____	5	\$ _____	\$ _____
46	48" x 48", R3-4-A (Standard Plan) NO U TURN (symbol)	15	\$ _____	\$ _____	0	\$ 0.00	\$ 0.00	0	\$ 0.00	\$ 0.00	0	\$ 0.00	\$ 0.00
47	24" x 18", R3-4b, (Standard Plan) NO U OR LEFT TURN (words)	50	\$ _____	\$ _____	0	\$ 0.00	\$ 0.00	0	\$ 0.00	\$ 0.00	0	\$ 0.00	\$ 0.00
48	24" x 24", R3-18 (MUTCD) NO U OR LEFT TURN (symbol)	50	\$ _____	\$ _____	12	\$ _____	\$ _____	0	\$ 0.00	\$ 0.00	0	\$ 0.00	\$ 0.00
49	24" x 18", R3-4p (Standard Plan) NO U TURN (words)	5	\$ _____	\$ _____	12	\$ _____	\$ _____	0	\$ 0.00	\$ 0.00	5	\$ _____	\$ _____
50	36" x 30", R3-5(R) (Standard Plan) (single turn right symbol and the words "ONLY")	25	\$ _____	\$ _____	12	\$ _____	\$ _____	0	\$ 0.00	\$ 0.00	0	\$ 0.00	\$ 0.00

FURNISHING AND DELIVERING TRAFFIC SIGNS  
PROJECT NO. HWY-C-09-23  
ISLANDS OF OAHU, HAWAII, MAUI AND KAUAI  
**PROPOSAL SCHEDULE**

**1. SIGNS, REGULATORY (REFLECTORIZED, HIGH INTENSITY PRISMATIC) (CONTINUATION):**

BID ITEM NO.	ITEM	OAHU DISTRICT			HAWAII DISTRICT			MAUI DISTRICT			KAUAI DISTRICT		
		EST. YEARLY QTY. (EACH) (A)	UNIT PRICE (B)	AMOUNT (A x B)	EST. YEARLY QTY. (EACH) (C)	UNIT PRICE (D)	AMOUNT (C x D)	EST. YEARLY QTY. (EACH) (E)	UNIT PRICE (F)	AMOUNT (E x F)	EST. YEARLY QTY. (EACH) (G)	UNIT PRICE (H)	AMOUNT (G x H)
51	48" x 60", R3-5(R) (single turn right symbol and the words "ONLY")	25	\$ _____	\$ _____	0	\$ 0.00	\$ 0.00	0	\$ 0.00	\$ 0.00	0	\$ 0.00	\$ 0.00
52	36" x 30", R3-5(L) (single turn left symbol and the words "ONLY")	25	\$ _____	\$ _____	12	\$ _____	\$ _____	0	\$ 0.00	\$ 0.00	0	\$ 0.00	\$ 0.00
53	30" x 30", R3-7(L) LEFT LANE MUST TURN LEFT	25	\$ _____	\$ _____	0	\$ 0.00	\$ 0.00	0	\$ 0.00	\$ 0.00	5	\$ _____	\$ _____
54	24" x 36", R3-9b (MUTCD) TWO WAY LEFT TURN LANE (turn left symbol from both directions with the words "CENTER LANE" and "ONLY")	30	\$ _____	\$ _____	0	\$ 0.00	\$ 0.00	0	\$ 0.00	\$ 0.00	5	\$ _____	\$ _____
55	36" x 48", R3-9b (MUTCD) TWO WAY LEFT TURN LANE (turn left symbol from both directions with the words "CENTER LANE" and "ONLY")	25	\$ _____	\$ _____	0	\$ 0.00	\$ 0.00	0	\$ 0.00	\$ 0.00	0	\$ 0.00	\$ 0.00
56	36" x 36", R3-7(R) RIGHT LANE MUST TURN RIGHT (words)	50	\$ _____	\$ _____	0	\$ 0.00	\$ 0.00	0	\$ 0.00	\$ 0.00	5	\$ _____	\$ _____

FURNISHING AND DELIVERING TRAFFIC SIGNS  
PROJECT NO. HWY-C-09-23  
ISLANDS OF OAHU, HAWAII, MAUI AND KAUAI  
**PROPOSAL SCHEDULE**

**1. SIGNS, REGULATORY (REFLECTORIZED, HIGH INTENSITY PRISMATIC) (CONTINUATION):**

BID ITEM NO.	ITEM	OAHU DISTRICT			HAWAII DISTRICT			MAUI DISTRICT			KAUAI DISTRICT		
		EST. YEARLY QTY. (EACH) (A)	UNIT PRICE (B)	AMOUNT (A x B)	EST. YEARLY QTY. (EACH) (C)	UNIT PRICE (D)	AMOUNT (C x D)	EST. YEARLY QTY. (EACH) (E)	UNIT PRICE (F)	AMOUNT (E x F)	EST. YEARLY QTY. (EACH) (G)	UNIT PRICE (H)	AMOUNT (G x H)
57	24" x 30", R3-16, Non-standard, Bicycle and preferential only lane (diamond) symbols and the words LANE AHEAD, Black with white retroreflective background. <i>Refer to Appendix D.</i>	25	\$ _____	\$ _____	0	\$ 0.00	\$ 0.00	10	\$ _____	\$ _____	5	\$ _____	\$ _____
58	24" x 30", R4-1 DO NOT PASS (words)	50	\$ _____	\$ _____	12	\$ _____	\$ _____	50	\$ _____	\$ _____	5	\$ _____	\$ _____
59	36" x 48", R4-1 DO NOT PASS (words)	25	\$ _____	\$ _____	0	\$ 0.00	\$ 0.00	0	\$ 0.00	\$ 0.00	5	\$ _____	\$ _____
60	48" x 60", R4-1-A (Standard plan) DO NOT PASS (words)	10	\$ _____	\$ _____	0	\$ 0.00	\$ 0.00	0	\$ 0.00	\$ 0.00	0	\$ 0.00	\$ 0.00
61	24" x 30", R4-2 PASS WITH CARE (words)	50	\$ _____	\$ _____	12	\$ _____	\$ _____	50	\$ _____	\$ _____	5	\$ _____	\$ _____
62	36" x 48", R4-2 PASS WITH CARE (words)	25	\$ _____	\$ _____	0	\$ 0.00	\$ 0.00	0	\$ 0.00	\$ 0.00	0	\$ 0.00	\$ 0.00
63	48" x 60", R4-2-A (Standard Plan) PASS WITH CARE (words)	10	\$ _____	\$ _____	0	\$ 0.00	\$ 0.00	0	\$ 0.00	\$ 0.00	0	\$ 0.00	\$ 0.00
64	36" x 48", R4-5 (Standard Plan) TRUCKS USE RIGHT LANE	10	\$ _____	\$ _____	0	\$ 0.00	\$ 0.00	0	\$ 0.00	\$ 0.00	0	\$ 0.00	\$ 0.00

FURNISHING AND DELIVERING TRAFFIC SIGNS  
PROJECT NO. HWY-C-09-23  
ISLANDS OF OAHU, HAWAII, MAUI AND KAUAI  
**PROPOSAL SCHEDULE**

**1. SIGNS, REGULATORY (REFLECTORIZED, HIGH INTENSITY PRISMATIC) (CONTINUATION):**

BID ITEM NO.	ITEM	OAHU DISTRICT			HAWAII DISTRICT			MAUI DISTRICT			KAUAI DISTRICT		
		EST. YEARLY QTY. (EACH) (A)	UNIT PRICE (B)	AMOUNT (A x B)	EST. YEARLY QTY. (EACH) (C)	UNIT PRICE (D)	AMOUNT (C x D)	EST. YEARLY QTY. (EACH) (E)	UNIT PRICE (F)	AMOUNT (E x F)	EST. YEARLY QTY. (EACH) (G)	UNIT PRICE (H)	AMOUNT (G x H)
65	48" x 60", R4-5-A (Standard Plan) TRUCKS USE RIGHT LANE	10	\$ _____	\$ _____	0	\$ 0.00	\$ 0.00	0	\$ 0.00	\$ 0.00	0	\$ 0.00	\$ 0.00
66	24" x 18", R4-7 plaque (Standard Plan) KEEP RIGHT (words only)	50	\$ _____	\$ _____	0	\$ 0.00	\$ 0.00	0	\$ 0.00	\$ 0.00	5	\$ _____	\$ _____
66a	24" x 30", R4-7 (MUTCD) KEEP RIGHT (symbol)	100	\$ _____	\$ _____	0	\$ 0.00	\$ 0.00	0	\$ 0.00	\$ 0.00	5	\$ _____	\$ _____
67	30" x 30", R5-1 DO NOT ENTER	100	\$ _____	\$ _____	48	\$ _____	\$ _____	50	\$ _____	\$ _____	5	\$ _____	\$ _____
68	36" x 36", R5-1 DO NOT ENTER	30	\$ _____	\$ _____	0	\$ 0.00	\$ 0.00	15	\$ _____	\$ _____	0	\$ 0.00	\$ 0.00
69	48" x 48", R5-1-A (Standard plan) DO NOT ENTER	10	\$ _____	\$ _____	0	\$ 0.00	\$ 0.00	0	\$ 0.00	\$ 0.00	0	\$ 0.00	\$ 0.00
70	30" x 18", R5-1a WRONG WAY	50	\$ _____	\$ _____	0	\$ 0.00	\$ 0.00	20	\$ _____	\$ _____	0	\$ 0.00	\$ 0.00
71	36" x 24", R5-1a WRONG WAY	50	\$ _____	\$ _____	24	\$ _____	\$ _____	0	\$ 0.00	\$ 0.00	5	\$ _____	\$ _____
72	42" x 30", R5-1a WRONG WAY	50	\$ _____	\$ _____	0	\$ 0.00	\$ 0.00	0	\$ 0.00	\$ 0.00	0	\$ 0.00	\$ 0.00
73	36" x 12", R6-1(R) ONE WAY (arrow)	300	\$ _____	\$ _____	12	\$ _____	\$ _____	12	\$ _____	\$ _____	5	\$ _____	\$ _____



FURNISHING AND DELIVERING TRAFFIC SIGNS  
PROJECT NO. HWY-C-09-23  
ISLANDS OF OAHU, HAWAII, MAUI AND KAUAI  
**PROPOSAL SCHEDULE**

**1. SIGNS, REGULATORY (REFLECTORIZED, HIGH INTENSITY PRISMATIC) (CONTINUATION):**

BID ITEM NO.	ITEM	OAHU DISTRICT			HAWAII DISTRICT			MAUI DISTRICT			KAUAI DISTRICT		
		EST. YEARLY QTY. (EACH) (A)	UNIT PRICE (B)	AMOUNT (A x B)	EST. YEARLY QTY. (EACH) (C)	UNIT PRICE (D)	AMOUNT (C x D)	EST. YEARLY QTY. (EACH) (E)	UNIT PRICE (F)	AMOUNT (E x F)	EST. YEARLY QTY. (EACH) (G)	UNIT PRICE (H)	AMOUNT (G x H)
74	36" x 12", R6-1(L) ONE WAY (arrow)	200	\$ _____	\$ _____	12	\$ _____	\$ _____	12	\$ _____	\$ _____	5	\$ _____	\$ _____
74a	24" x 18", R7-1 (Standard plan) NO PARKING ANYTIME (w/ double arrow)	200	\$ _____	\$ _____	12	\$ _____	\$ _____	0	\$ 0.00	\$ 0.00	10	\$ _____	\$ _____
75	24" x 30", R7-1-A (Standard plan) NO PARKING ANYTIME (w/ double arrow)	100	\$ _____	\$ _____	12	\$ _____	\$ _____	0	\$ 0.00	\$ 0.00	10	\$ _____	\$ _____
75a	12" x 18", R7-1 (Standard plan) NO PARKING ANYTIME (w/ double arrow)	200	\$ _____	\$ _____	0	\$ 0.00	\$ 0.00	20	\$ _____	\$ _____	10	\$ _____	\$ _____
75b	18" x 24", R7-1 (Standard plan, non-standard) NO PARKING ANYTIME (w/ double arrow)	50	\$ _____	\$ _____	0	\$ 0.00	\$ 0.00	0	\$ 0.00	\$ 0.00	10	\$ _____	\$ _____
76	12" x 6", R7-201P (MUTCD) TOW-AWAY ZONE (symbol)	300	\$ _____	\$ _____	0	\$ 0.00	\$ 0.00	100	\$ _____	\$ _____	10	\$ _____	\$ _____
77	24" x 12", R7-201a (MUTCD) TOW-AWAY ZONE (symbol)	200	\$ _____	\$ _____	0	\$ 0.00	\$ 0.00	0	\$ 0.00	\$ 0.00	0	\$ 0.00	\$ 0.00
77a	12" x 18", R7-4 (MUTCD) NO STOPPING OR STANDING	50	\$ _____	\$ _____	0	\$ 0.00	\$ 0.00	0	\$ 0.00	\$ 0.00	0	\$ 0.00	\$ 0.00
77b	24" x 30", R7-4 (MUTCD) NO STOPPING OR STANDING	50	\$ _____	\$ _____	0	\$ 0.00	\$ 0.00	0	\$ 0.00	\$ 0.00	0	\$ 0.00	\$ 0.00

FURNISHING AND DELIVERING TRAFFIC SIGNS  
PROJECT NO. HWY-C-09-23  
ISLANDS OF OAHU, HAWAII, MAUI AND KAUAI  
**PROPOSAL SCHEDULE**

**1. SIGNS, REGULATORY (REFLECTORIZED, HIGH INTENSITY PRISMATIC) (CONTINUATION):**

BID ITEM NO.	ITEM	OAHU DISTRICT			HAWAII DISTRICT			MAUI DISTRICT			KAUAI DISTRICT		
		EST. YEARLY QTY. (EACH) (A)	UNIT PRICE (B)	AMOUNT (A x B)	EST. YEARLY QTY. (EACH) (C)	UNIT PRICE (D)	AMOUNT (C x D)	EST. YEARLY QTY. (EACH) (E)	UNIT PRICE (F)	AMOUNT (E x F)	EST. YEARLY QTY. (EACH) (G)	UNIT PRICE (H)	AMOUNT (G x H)
77c	12" x 18", R7-9a (MUTCD) NO PARKING, BIKE LANE	50	\$ _____	\$ _____	0	\$ 0.00	\$ 0.00	0	\$ 0.00	\$ 0.00	0	\$ 0.00	\$ 0.00
78	24" x 24", R8-1 NO PARKING ON PAVEMENT	20	\$ _____	\$ _____	0	\$ 0.00	\$ 0.00	0	\$ 0.00	\$ 0.00	0	\$ 0.00	\$ 0.00
79	24" x 30", R8-1 NO PARKING ON PAVEMENT	20	\$ _____	\$ _____	0	\$ 0.00	\$ 0.00	0	\$ 0.00	\$ 0.00	0	\$ 0.00	\$ 0.00
80	24" x 24", R8-3 (MUTCD) NO PARKING (symbol)	200	\$ _____	\$ _____	0	\$ 0.00	\$ 0.00	100	\$ _____	\$ _____	15	\$ _____	\$ _____
81	48" x 48", R8-3 (MUTCD) NO PARKING (symbol)	10	\$ _____	\$ _____	0	\$ 0.00	\$ 0.00	0	\$ 0.00	\$ 0.00	0	\$ 0.00	\$ 0.00
82	24" x 30", R8-4 EMERGENCY PARKING ONLY	25	\$ _____	\$ _____	0	\$ 0.00	\$ 0.00	0	\$ 0.00	\$ 0.00	0	\$ 0.00	\$ 0.00
83	48" x 36", R8-7-A (Standard Plan) EMERGENCY STOPPING ONLY	25	\$ _____	\$ _____	0	\$ 0.00	\$ 0.00	0	\$ 0.00	\$ 0.00	0	\$ 0.00	\$ 0.00
84	24" x 36", R10-6 STOP HERE ON RED (non-curved arrow)	50	\$ _____	\$ _____	0	\$ 0.00	\$ 0.00	0	\$ 0.00	\$ 0.00	0	\$ 0.00	\$ 0.00
85	24" x 30", R10-11a NO RIGHT TURN ON RED	20	\$ _____	\$ _____	0	\$ 0.00	\$ 0.00	0	\$ 0.00	\$ 0.00	5	\$ _____	\$ _____

FURNISHING AND DELIVERING TRAFFIC SIGNS  
PROJECT NO. HWY-C-09-23  
ISLANDS OF OAHU, HAWAII, MAUI AND KAUAI  
**PROPOSAL SCHEDULE**

**1. SIGNS, REGULATORY (REFLECTORIZED, HIGH INTENSITY PRISMATIC) (CONTINUATION):**

BID ITEM NO.	ITEM	OAHU DISTRICT			HAWAII DISTRICT			MAUI DISTRICT			KAUAI DISTRICT		
		EST. YEARLY QTY. (EACH) (A)	UNIT PRICE (B)	AMOUNT (A x B)	EST. YEARLY QTY. (EACH) (C)	UNIT PRICE (D)	AMOUNT (C x D)	EST. YEARLY QTY. (EACH) (E)	UNIT PRICE (F)	AMOUNT (E x F)	EST. YEARLY QTY. (EACH) (G)	UNIT PRICE (H)	AMOUNT (G x H)
86	36" x 36", R10-11c (modified, MUTCD) non-standard, NO RIGHT TURN ON RED EXCEPT FROM RIGHT LANE AFTER STOP <i>Refer to Appendix D1</i>	25	\$ _____	\$ _____	0	\$ 0.00	\$ 0.00	0	\$ 0.00	\$ 0.00	0	\$ 0.00	\$ 0.00
87	24" x 30", R10-12 LEFT TURN YIELD ON GREEN (ball)	25	\$ _____	\$ _____	0	\$ 0.00	\$ 0.00	0	\$ 0.00	\$ 0.00	5	\$ _____	\$ _____
88	24" x 30", R11-1 KEEP OFF MEDIAN	50	\$ _____	\$ _____	0	\$ 0.00	\$ 0.00	15	\$ _____	\$ _____	0	\$ 0.00	\$ 0.00
89	36" x 48", R11-1 KEEP OFF MEDIAN	25	\$ _____	\$ _____	0	\$ 0.00	\$ 0.00	0	\$ 0.00	\$ 0.00	0	\$ 0.00	\$ 0.00
90	36" x 42", Non-standard, TRUCKS TEST BRAKES (words). <i>Refer to Appendix E</i>	10	\$ _____	\$ _____	0	\$ 0.00	\$ 0.00	0	\$ 0.00	\$ 0.00	0	\$ 0.00	\$ 0.00
91	36" x 42", R16-5 UNLICENSED VEHICLES, BICYCLES, CYCLES UNDER 5HP, PEDESTRIANS KEEP OUT OF FREEWAY	200	\$ _____	\$ _____	0	\$ 0.00	\$ 0.00	0	\$ 0.00	\$ 0.00	0	\$ 0.00	\$ 0.00
92	24" x 30", R16-6 U TURN AHEAD (words only) <i>Refer to the Standard Plan TE-06 and Appendix A</i>	50	\$ _____	\$ _____	0	\$ 0.00	\$ 0.00	0	\$ 0.00	\$ 0.00	0	\$ 0.00	\$ 0.00

FURNISHING AND DELIVERING TRAFFIC SIGNS  
PROJECT NO. HWY-C-09-23  
ISLANDS OF OAHU, HAWAII, MAUI AND KAUAI  
**PROPOSAL SCHEDULE**

**1. SIGNS, REGULATORY (REFLECTORIZED, HIGH INTENSITY PRISMATIC) (CONTINUATION):**

BID ITEM NO.	ITEM	OAHU DISTRICT			HAWAII DISTRICT			MAUI DISTRICT			KAUAI DISTRICT		
		EST. YEARLY QTY. (EACH) (A)	UNIT PRICE (B)	AMOUNT (A x B)	EST. YEARLY QTY. (EACH) (C)	UNIT PRICE (D)	AMOUNT (C x D)	EST. YEARLY QTY. (EACH) (E)	UNIT PRICE (F)	AMOUNT (E x F)	EST. YEARLY QTY. (EACH) (G)	UNIT PRICE (H)	AMOUNT (G x H)
93	30" x 48", R17-2 (modified, Standard Plan) non-standard, 2 left lanes and 1 U turn symbols with words "ON LEFT ARROW ONLY U TURN OK" <i>Refer to Appendix E1</i>	100	\$ _____	\$ _____	0	\$ 0.00	\$ 0.00	0	\$ 0.00	\$ 0.00	0	\$ 0.00	\$ 0.00
94	30" x 48", R17-3 (modified, Standard Plan) non-standard, ON LEFT ARROW ONLY NO U TURN (single turn left symbol and words "ON LEFT ARROW ONLY NO U TURN") <i>Refer to Appendix E2</i>	50	\$ _____	\$ _____	0	\$ 0.00	\$ 0.00	0	\$ 0.00	\$ 0.00	0	\$ 0.00	\$ 0.00
95	30" x 48", R17-3 (modified, Standard Plan) non-standard, ON LEFT ARROW ONLY (single arrow symbol and words) <i>Refer to Appendix E3</i>	50	\$ _____	\$ _____	0	\$ 0.00	\$ 0.00	0	\$ 0.00	\$ 0.00	0	\$ 0.00	\$ 0.00
96	30" x 48", R17-3(L) U TURN OK ON LEFT ARROW (combined turn left and U turn symbol and words "ON LEFT ARROW ONLY U TURN OK") <i>Refer to Appendix E4</i>	100	\$ _____	\$ _____	0	\$ 0.00	\$ 0.00	0	\$ 0.00	\$ 0.00	0	\$ 0.00	\$ 0.00

FURNISHING AND DELIVERING TRAFFIC SIGNS  
PROJECT NO. HWY-C-09-23  
ISLANDS OF OAHU, HAWAII, MAUI AND KAUAI  
**PROPOSAL SCHEDULE**

**1. SIGNS, REGULATORY (REFLECTORIZED, HIGH INTENSITY PRISMATIC) (CONTINUATION):**

BID ITEM NO.	ITEM	OAHU DISTRICT			HAWAII DISTRICT			MAUI DISTRICT			KAUAI DISTRICT		
		EST. YEARLY QTY. (EACH) (A)	UNIT PRICE (B)	AMOUNT (A x B)	EST. YEARLY QTY. (EACH) (C)	UNIT PRICE (D)	AMOUNT (C x D)	EST. YEARLY QTY. (EACH) (E)	UNIT PRICE (F)	AMOUNT (E x F)	EST. YEARLY QTY. (EACH) (G)	UNIT PRICE (H)	AMOUNT (G x H)
97	30" x 48", R17-4 (modified, Standard Plan) Non-standard, U TURN OK ON LEFT ARROW (combined 2 turn left symbols and words "ON LEFT ARROW ONLY NO U TURN") <i>Refer to Appendix F</i>	25	\$ _____	\$ _____	10	\$ _____	\$ _____	0	\$ 0.00	\$ 0.00	0	\$ 0.00	\$ 0.00
98	24" x 30", Non-standard, NO DUMPING (words) <i>Refer to Appendix G</i>	40	\$ _____	\$ _____	0	\$ 0.00	\$ 0.00	0	\$ 0.00	\$ 0.00	0	\$ 0.00	\$ 0.00
99	24" x 30", Non-standard, NO JUMPING FROM BRIDGE <i>Refer to Appendix G1</i>	25	\$ _____	\$ _____	0	\$ 0.00	\$ 0.00	0	\$ 0.00	\$ 0.00	4	\$ _____	\$ _____
100	24" x 30", Non-standard, NO VENDING <i>Refer to Appendix G2</i>	50	\$ _____	\$ _____	0	\$ 0.00	\$ 0.00	15	\$ _____	\$ _____	5	\$ _____	\$ _____
100a	48" x 24", Non-standard, KEEP OUT GOVERNMENT PROPERTY TRESPASSERS WILL BE PROSECUTED STATE DEPARTMENT OF TRANSPORTATION HIGHWAYS DIVISION HRS 264-12, HRS 264-6, HRS 708-815 <i>Refer to Appendix G3</i>	50	\$ _____	\$ _____	0	\$ 0.00	\$ 0.00	30	\$ _____	\$ _____	0	\$ 0.00	\$ 0.00
<b>SUBTOTAL 1</b> (SUM OF BID ITEM NOS. 1 THRU 100a FOR EACH RESPECTIVE DISTRICT)		\$ _____			\$ _____			\$ _____			\$ _____		

FURNISHING AND DELIVERING TRAFFIC SIGNS  
PROJECT NO. HWY-C-09-23  
ISLANDS OF OAHU, HAWAII, MAUI AND KAUAI  
**PROPOSAL SCHEDULE**

**2. SIGNS, WARNING (REFLECTORIZED, HIGH INTENSITY PRISMATIC):**

BID ITEM NO.	ITEM	OAHU DISTRICT			HAWAII DISTRICT			MAUI DISTRICT			KAUAI DISTRICT		
		EST. YEARLY QTY. (EACH) (A)	UNIT PRICE (B)	AMOUNT (A x B)	EST. YEARLY QTY. (EACH) (C)	UNIT PRICE (D)	AMOUNT (C x D)	EST. YEARLY QTY. (EACH) (E)	UNIT PRICE (F)	AMOUNT (E x F)	EST. YEARLY QTY. (EACH) (G)	UNIT PRICE (H)	AMOUNT (G x H)
101	30" x 30", W1-1(R) (Standard Plan) TURN (symbol)	20	\$ _____	\$ _____	12	\$ _____	\$ _____	0	\$ 0.00	\$ 0.00	0	\$ 0.00	\$ 0.00
102	36" x 36", W1-1(R) (MUTCD) TURN (symbol)	10	\$ _____	\$ _____	6	\$ _____	\$ _____	0	\$ 0.00	\$ 0.00	0	\$ 0.00	\$ 0.00
103	48" x 48", W1-1(R)-A (Standard Plan) TURN (symbol)	10	\$ _____	\$ _____	0	\$ 0.00	\$ 0.00	0	\$ 0.00	\$ 0.00	0	\$ 0.00	\$ 0.00
104	30" x 30", W1-1(L) (MUTCD) TURN (symbol)	20	\$ _____	\$ _____	12	\$ _____	\$ _____	0	\$ 0.00	\$ 0.00	0	\$ 0.00	\$ 0.00
105	36" x 36", W1-1(L) (MUTCD) TURN (symbol)	20	\$ _____	\$ _____	6	\$ _____	\$ _____	0	\$ 0.00	\$ 0.00	0	\$ 0.00	\$ 0.00
106	30" x 30", W1-2(L) (MUTCD) CURVE (symbol)	20	\$ _____	\$ _____	12	\$ _____	\$ _____	0	\$ 0.00	\$ 0.00	10	\$ _____	\$ _____
107	36" x 36", W1-2(L) (MUTCD) CURVE (symbol)	20	\$ _____	\$ _____	6	\$ _____	\$ _____	0	\$ 0.00	\$ 0.00	0	\$ 0.00	\$ 0.00
108	48" x 48", W1-2(L)-A (Standard Plan) CURVE (symbol)	10	\$ _____	\$ _____	0	\$ 0.00	\$ 0.00	0	\$ 0.00	\$ 0.00	0	\$ 0.00	\$ 0.00
109	30" x 30", W1-2(R) (MUTCD) CURVE (symbol)	20	\$ _____	\$ _____	12	\$ _____	\$ _____	0	\$ 0.00	\$ 0.00	10	\$ _____	\$ _____

FURNISHING AND DELIVERING TRAFFIC SIGNS  
PROJECT NO. HWY-C-09-23  
ISLANDS OF OAHU, HAWAII, MAUI AND KAUAI  
**PROPOSAL SCHEDULE**

**2. SIGNS, WARNING (REFLECTORIZED, HIGH INTENSITY PRISMATIC) (CONTINUATION):**

BID ITEM NO.	ITEM	OAHU DISTRICT			HAWAII DISTRICT			MAUI DISTRICT			KAUAI DISTRICT		
		EST. YEARLY QTY. (EACH) (A)	UNIT PRICE (B)	AMOUNT (A x B)	EST. YEARLY QTY. (EACH) (C)	UNIT PRICE (D)	AMOUNT (C x D)	EST. YEARLY QTY. (EACH) (E)	UNIT PRICE (F)	AMOUNT (E x F)	EST. YEARLY QTY. (EACH) (G)	UNIT PRICE (H)	AMOUNT (G x H)
110	36" x 36", W1-2(R) (MUTCD) CURVE (symbol)	10	\$ _____	\$ _____	6	\$ _____	\$ _____	0	\$ 0.00	\$ 0.00	10	\$ _____	\$ _____
111	48" x 48", W1-2(R)-A (Standard Plan) CURVE (symbol)	20	\$ _____	\$ _____	0	\$ 0.00	\$ 0.00	0	\$ 0.00	\$ 0.00	0	\$ 0.00	\$ 0.00
112	30" x 30", W1-4(L) (MUTCD) REVERSE CURVE (symbol)	10	\$ _____	\$ _____	6	\$ _____	\$ _____	0	\$ 0.00	\$ 0.00	10	\$ _____	\$ _____
112a	36" x 36", W1-4(L) (MUTCD) REVERSE CURVE (symbol)	20	\$ _____	\$ _____	0	\$ 0.00	\$ 0.00	0	\$ 0.00	\$ 0.00	10	\$ _____	\$ _____
112b	36" x 36", W1-4(R) (MUTCD) REVERSE CURVE (symbol)	20	\$ _____	\$ _____	0	\$ 0.00	\$ 0.00	0	\$ 0.00	\$ 0.00	10	\$ _____	\$ _____
113	30" x 30", W1-5(L) (MUTCD) WINDING ROAD (symbol)	25	\$ _____	\$ _____	0	\$ 0.00	\$ 0.00	0	\$ 0.00	\$ 0.00	0	\$ 0.00	\$ 0.00
113a	36" x 36", W1-5(L) (MUTCD) WINDING ROAD (symbol)	10	\$ _____	\$ _____	6	\$ _____	\$ _____	0	\$ 0.00	\$ 0.00	5	\$ _____	\$ _____
114	30" x 30", W1-5(R) (Standard Plan) WINDING ROAD (symbol)	20	\$ _____	\$ _____	6	\$ _____	\$ _____	0	\$ 0.00	\$ 0.00	5	\$ _____	\$ _____

FURNISHING AND DELIVERING TRAFFIC SIGNS  
PROJECT NO. HWY-C-09-23  
ISLANDS OF OAHU, HAWAII, MAUI AND KAUAI  
**PROPOSAL SCHEDULE**

**2. SIGNS, WARNING (REFLECTORIZED, HIGH INTENSITY PRISMATIC) (CONTINUATION):**

BID ITEM NO.	ITEM	OAHU DISTRICT			HAWAII DISTRICT			MAUI DISTRICT			KAUAI DISTRICT		
		EST. YEARLY QTY. (EACH) (A)	UNIT PRICE (B)	AMOUNT (A x B)	EST. YEARLY QTY. (EACH) (C)	UNIT PRICE (D)	AMOUNT (C x D)	EST. YEARLY QTY. (EACH) (E)	UNIT PRICE (F)	AMOUNT (E x F)	EST. YEARLY QTY. (EACH) (G)	UNIT PRICE (H)	AMOUNT (G x H)
115	36" x 36", W1-5(R) (MUTCD) WINDING ROAD (symbol)	10	\$ _____	\$ _____	6	\$ _____	\$ _____	0	\$ 0.00	\$ 0.00	2	\$ _____	\$ _____
116	48" x 24", W1-6 LARGE ARROW (one direction)	5	\$ _____	\$ _____	6	\$ _____	\$ _____	0	\$ 0.00	\$ 0.00	2	\$ _____	\$ _____
117	48" x 24", W1-7 LARGE ARROW (two direction)	5	\$ _____	\$ _____	6	\$ _____	\$ _____	0	\$ 0.00	\$ 0.00	0	\$ 0.00	\$ 0.00
118	18" x 24", W1-8(R) (MUTCD) CHEVRON	20	\$ _____	\$ _____	48	\$ _____	\$ _____	100	\$ _____	\$ _____	10	\$ _____	\$ _____
119	24" x 30", W1-8(R) (MUTCD) CHEVRON	24	\$ _____	\$ _____	24	\$ _____	\$ _____	50	\$ _____	\$ _____	10	\$ _____	\$ _____
120	30" x 36", W1-8(R)-A (Standard Plan) CHEVRON	50	\$ _____	\$ _____	0	\$ 0.00	\$ 0.00	30	\$ _____	\$ _____	10	\$ _____	\$ _____
121	30" x 30", W2-1 CROSS ROAD (symbol)	20	\$ _____	\$ _____	12	\$ _____	\$ _____	0	\$ 0.00	\$ 0.00	0	\$ 0.00	\$ 0.00
122	36" x 36", W2-1 CROSS ROAD (symbol)	20	\$ _____	\$ _____	12	\$ _____	\$ _____	0	\$ 0.00	\$ 0.00	0	\$ 0.00	\$ 0.00
123	30" x 30", W2-2(R) (Standard Plan) SIDE ROAD (symbol)	50	\$ _____	\$ _____	24	\$ _____	\$ _____	0	\$ 0.00	\$ 0.00	0	\$ 0.00	\$ 0.00



FURNISHING AND DELIVERING TRAFFIC SIGNS  
PROJECT NO. HWY-C-09-23  
ISLANDS OF OAHU, HAWAII, MAUI AND KAUAI  
**PROPOSAL SCHEDULE**

**2. SIGNS, WARNING (REFLECTORIZED, HIGH INTENSITY PRISMATIC) (CONTINUATION):**

BID ITEM NO.	ITEM	OAHU DISTRICT			HAWAII DISTRICT			MAUI DISTRICT			KAUAI DISTRICT		
		EST. YEARLY QTY. (EACH) (A)	UNIT PRICE (B)	AMOUNT (A x B)	EST. YEARLY QTY. (EACH) (C)	UNIT PRICE (D)	AMOUNT (C x D)	EST. YEARLY QTY. (EACH) (E)	UNIT PRICE (F)	AMOUNT (E x F)	EST. YEARLY QTY. (EACH) (G)	UNIT PRICE (H)	AMOUNT (G x H)
124	36" x 36", W2-2(R) (Standard Plan) SIDE ROAD (symbol)	25	\$ _____	\$ _____	12	\$ _____	\$ _____	0	\$ 0.00	\$ 0.00	0	\$ 0.00	\$ 0.00
125	36" x 36", W2-5 Y INTERSECTION (symbol)	5	\$ _____	\$ _____	6	\$ _____	\$ _____	0	\$ 0.00	\$ 0.00	0	\$ 0.00	\$ 0.00
126	36" x 36", W3-1 STOP AHEAD (symbol)	50	\$ _____	\$ _____	0	\$ 0.00	\$ 0.00	10	\$ _____	\$ _____	0	\$ 0.00	\$ 0.00
127	24" x 18", W3-1P STOP AHEAD (modified, MUTCD) <i>Refer to Appendix N</i>	25	\$ _____	\$ _____	0	\$ 0.00	\$ 0.00	0	\$ 0.00	\$ 0.00	0	\$ 0.00	\$ 0.00
128	36" x 36", W3-3 TRAFFIC SIGNAL AHEAD (symbol)	50	\$ _____	\$ _____	0	\$ 0.00	\$ 0.00	10	\$ _____	\$ _____	2	\$ _____	\$ _____
129	36" x 36", W3-2 YIELD AHEAD (symbol)	50	\$ _____	\$ _____	0	\$ 0.00	\$ 0.00	10	\$ _____	\$ _____	0	\$ 0.00	\$ 0.00
130	48" x 48", W3-4, (Standard Plan) STOP AHEAD WHEN FLASHING (words)	50	\$ _____	\$ _____	0	\$ 0.00	\$ 0.00	0	\$ 0.00	\$ 0.00	2	\$ _____	\$ _____
131	36" x 36", W3-5 (35) (MUTCD) SPEED REDUCTION AHEAD	6	\$ _____	\$ _____	0	\$ 0.00	\$ 0.00	0	\$ 0.00	\$ 0.00	0	\$ 0.00	\$ 0.00
132	36" x 36", W3-5 (MUTCD) SPEED REDUCTION AHEAD (blank)	40	\$ _____	\$ _____	24	\$ _____	\$ _____	0	\$ 0.00	\$ 0.00	5	\$ _____	\$ _____

FURNISHING AND DELIVERING TRAFFIC SIGNS  
PROJECT NO. HWY-C-09-23  
ISLANDS OF OAHU, HAWAII, MAUI AND KAUAI  
**PROPOSAL SCHEDULE**

**2. SIGNS, WARNING (REFLECTORIZED, HIGH INTENSITY PRISMATIC) (CONTINUATION):**

BID ITEM NO.	ITEM	OAHU DISTRICT			HAWAII DISTRICT			MAUI DISTRICT			KAUAI DISTRICT		
		EST. YEARLY QTY. (EACH) (A)	UNIT PRICE (B)	AMOUNT (A x B)	EST. YEARLY QTY. (EACH) (C)	UNIT PRICE (D)	AMOUNT (C x D)	EST. YEARLY QTY. (EACH) (E)	UNIT PRICE (F)	AMOUNT (E x F)	EST. YEARLY QTY. (EACH) (G)	UNIT PRICE (H)	AMOUNT (G x H)
133	48" x 48", W3-5 (MUTCD) SPEED REDUCTION AHEAD (blank)	20	\$ _____	\$ _____	0	\$ 0.00	\$ 0.00	0	\$ 0.00	\$ 0.00	0	\$ 0.00	\$ 0.00
134	48" x 48", W8-6 (modified, MUTCD) Non-standard, "TRUCK CROSSING WHEN FLASHING" (words) <i>Refer to Appendix H</i>	10	\$ _____	\$ _____	0	\$ 0.00	\$ 0.00	0	\$ 0.00	\$ 0.00	0	\$ 0.00	\$ 0.00
135	36" x 36", W4-1(L) (MUTCD) MERGE LEFT (symbol)	25	\$ _____	\$ _____	12	\$ _____	\$ _____	0	\$ 0.00	\$ 0.00	0	\$ 0.00	\$ 0.00
136	48" x 48", W4-1(L)-A (Standard Plan) MERGE LEFT (symbol)	20	\$ _____	\$ _____	0	\$ 0.00	\$ 0.00	0	\$ 0.00	\$ 0.00	0	\$ 0.00	\$ 0.00
137	36" x 36", W4-1(R) (Standard Plan) MERGE (symbol)	20	\$ _____	\$ _____	12	\$ _____	\$ _____	0	\$ 0.00	\$ 0.00	0	\$ 0.00	\$ 0.00
138	36" x 36", W4-2(R) (Standard Plan) RIGHT LANE ENDS MERGE LEFT (symbol)	25	\$ _____	\$ _____	0	\$ 0.00	\$ 0.00	0	\$ 0.00	\$ 0.00	2	\$ _____	\$ _____
139	36" x 36", W4-2(L) (MUTCD) LEFT LANE ENDS MERGE RIGHT (symbol)	10	\$ _____	\$ _____	0	\$ 0.00	\$ 0.00	0	\$ 0.00	\$ 0.00	0	\$ 0.00	\$ 0.00
140	48" x 48", W4-2(L)-A (Standard Plan) LEFT LANE ENDS MERGE RIGHT (symbol)	10	\$ _____	\$ _____	0	\$ 0.00	\$ 0.00	0	\$ 0.00	\$ 0.00	0	\$ 0.00	\$ 0.00

FURNISHING AND DELIVERING TRAFFIC SIGNS  
PROJECT NO. HWY-C-09-23  
ISLANDS OF OAHU, HAWAII, MAUI AND KAUAI  
**PROPOSAL SCHEDULE**

**2. SIGNS, WARNING (REFLECTORIZED, HIGH INTENSITY PRISMATIC) (CONTINUATION):**

BID ITEM NO.	ITEM	OAHU DISTRICT			HAWAII DISTRICT			MAUI DISTRICT			KAUAI DISTRICT		
		EST. YEARLY QTY. (EACH) (A)	UNIT PRICE (B)	AMOUNT (A x B)	EST. YEARLY QTY. (EACH) (C)	UNIT PRICE (D)	AMOUNT (C x D)	EST. YEARLY QTY. (EACH) (E)	UNIT PRICE (F)	AMOUNT (E x F)	EST. YEARLY QTY. (EACH) (G)	UNIT PRICE (H)	AMOUNT (G x H)
141	36" x 36", W4-3(R) (Standard Plan) ADDED LANE (symbol)	20	\$ _____	\$ _____	0	\$ 0.00	\$ 0.00	0	\$ 0.00	\$ 0.00	0	\$ 0.00	\$ 0.00
142	36" x 36", W6-1 DIVIDED HIGHWAY (symbol)	25	\$ _____	\$ _____	0	\$ 0.00	\$ 0.00	0	\$ 0.00	\$ 0.00	2	\$ _____	\$ _____
143	48" x 48", W6-1-A (Standard Plan) DIVIDED HIGHWAY (symbol)	10	\$ _____	\$ _____	0	\$ 0.00	\$ 0.00	0	\$ 0.00	\$ 0.00	0	\$ 0.00	\$ 0.00
143a	36" x 36", W7-1 (MUTCD) HILL (symbol)	30	\$ _____	\$ _____	0	\$ 0.00	\$ 0.00	0	\$ 0.00	\$ 0.00	5	\$ _____	\$ _____
144	36" x 36", W8-2-A (Standard Plan) DIP (word)	10	\$ _____	\$ _____	0	\$ 0.00	\$ 0.00	0	\$ 0.00	\$ 0.00	0	\$ 0.00	\$ 0.00
145	36" x 36", W9-2(L) LANE ENDS MERGE LEFT (words)	25	\$ _____	\$ _____	0	\$ 0.00	\$ 0.00	0	\$ 0.00	\$ 0.00	5	\$ _____	\$ _____
146	36" x 36", W8-5 (MUTCD) SLIPPERY WHEN WET (symbol)	25	\$ _____	\$ _____	6	\$ _____	\$ _____	0	\$ 0.00	\$ 0.00	2	\$ _____	\$ _____
146a	48" x 48", W8-5 (MUTCD) SLIPPERY WHEN WET (symbol)	25	\$ _____	\$ _____	0	\$ 0.00	\$ 0.00	0	\$ 0.00	\$ 0.00	0	\$ 0.00	\$ 0.00

FURNISHING AND DELIVERING TRAFFIC SIGNS  
PROJECT NO. HWY-C-09-23  
ISLANDS OF OAHU, HAWAII, MAUI AND KAUAI  
**PROPOSAL SCHEDULE**

**2. SIGNS, WARNING (REFLECTORIZED, HIGH INTENSITY PRISMATIC) (CONTINUATION):**

BID ITEM NO.	ITEM	OAHU DISTRICT			HAWAII DISTRICT			MAUI DISTRICT			KAUAI DISTRICT		
		EST. YEARLY QTY. (EACH) (A)	UNIT PRICE (B)	AMOUNT (A x B)	EST. YEARLY QTY. (EACH) (C)	UNIT PRICE (D)	AMOUNT (C x D)	EST. YEARLY QTY. (EACH) (E)	UNIT PRICE (F)	AMOUNT (E x F)	EST. YEARLY QTY. (EACH) (G)	UNIT PRICE (H)	AMOUNT (G x H)
147	48" x 48", W9-2(L)-A (Standard Plan) LANE ENDS MERGE LEFT (words)	10	\$ _____	\$ _____	0	\$ 0.00	\$ 0.00	0	\$ 0.00	\$ 0.00	0	\$ 0.00	\$ 0.00
148	36" x 36", Non-standard "RUMBLE STRIPS AHEAD" (words) <i>Refer to Appendix I</i>	10	\$ _____	\$ _____	6	\$ _____	\$ _____	0	\$ 0.00	\$ 0.00	5	\$ _____	\$ _____
149	30" x 30", W11-1 (MUTCD) BICYCLE TRAFFIC (symbol)	40	\$ _____	\$ _____	0	\$ 0.00	\$ 0.00	0	\$ 0.00	\$ 0.00	0	\$ 0.00	\$ 0.00
149a	36" x 36", W11-1 (MUTCD) BICYCLE TRAFFIC (symbol)	21	\$ _____	\$ _____	12	\$ _____	\$ _____	0	\$ 0.00	\$ 0.00	0	\$ 0.00	\$ 0.00
150	36" x 36", W11-2 PED XING (symbol) (with lime green diamond grade fluorescent reflective sheeting)	200	\$ _____	\$ _____	0	\$ 0.00	\$ 0.00	10	\$ _____	\$ _____	0	\$ 0.00	\$ 0.00
151	36" x 36", W11-4 (MUTCD) CATTLE (symbol)	10	\$ _____	\$ _____	0	\$ 0.00	\$ 0.00	0	\$ 0.00	\$ 0.00	2	\$ _____	\$ _____
152	36" x 36", W11-7 EQUESTRIAN	20	\$ _____	\$ _____	0	\$ 0.00	\$ 0.00	0	\$ 0.00	\$ 0.00	0	\$ 0.00	\$ 0.00
153	36" x 36", W11-8 EMERGENCY VEHICLE (symbol)	10	\$ _____	\$ _____	0	\$ 0.00	\$ 0.00	0	\$ 0.00	\$ 0.00	0	\$ 0.00	\$ 0.00

FURNISHING AND DELIVERING TRAFFIC SIGNS  
PROJECT NO. HWY-C-09-23  
ISLANDS OF OAHU, HAWAII, MAUI AND KAUAI  
**PROPOSAL SCHEDULE**

**2. SIGNS, WARNING (REFLECTORIZED, HIGH INTENSITY PRISMATIC) (CONTINUATION):**

BID ITEM NO.	ITEM	OAHU DISTRICT			HAWAII DISTRICT			MAUI DISTRICT			KAUAI DISTRICT		
		EST. YEARLY QTY. (EACH) (A)	UNIT PRICE (B)	AMOUNT (A x B)	EST. YEARLY QTY. (EACH) (C)	UNIT PRICE (D)	AMOUNT (C x D)	EST. YEARLY QTY. (EACH) (E)	UNIT PRICE (F)	AMOUNT (E x F)	EST. YEARLY QTY. (EACH) (G)	UNIT PRICE (H)	AMOUNT (G x H)
154	24" x 24", W12-1 DOUBLE ARROW (symbol)	10	\$ _____	\$ _____	0	\$ 0.00	\$ 0.00	0	\$ 0.00	\$ 0.00	0	\$ 0.00	\$ 0.00
155	36" x 36", W12-1 DOUBLE ARROW (symbol)	10	\$ _____	\$ _____	0	\$ 0.00	\$ 0.00	0	\$ 0.00	\$ 0.00	0	\$ 0.00	\$ 0.00
156	18" x 18", W13-1 (25) (MUTCD) ADVISORY SPEED 25 M P H (words)	25	\$ _____	\$ _____	0	\$ 0.00	\$ 0.00	0	\$ 0.00	\$ 0.00	0	\$ 0.00	\$ 0.00
157	18" x 18", W13-1 (xx) (MUTCD) ADVISORY SPEED (blank)	25	\$ _____	\$ _____	0	\$ 0.00	\$ 0.00	20	\$ _____	\$ _____	0	\$ 0.00	\$ 0.00
157a	24" x 24", W13-1 (xx) (MUTCD) ADVISORY SPEED (blank)	25	\$ _____	\$ _____	0	\$ 0.00	\$ 0.00	0	\$ 0.00	\$ 0.00	0	\$ 0.00	\$ 0.00
158	36" x 48", W13-2 (35) (MUTCD) ADVISORY SPEED [EXIT] (35 M P H)	10	\$ _____	\$ _____	0	\$ 0.00	\$ 0.00	0	\$ 0.00	\$ 0.00	0	\$ 0.00	\$ 0.00
159	48" x 60", W13-2 (MUTCD) ADVISORY EXIT SPEED (blank)	30	\$ _____	\$ _____	0	\$ 0.00	\$ 0.00	0	\$ 0.00	\$ 0.00	0	\$ 0.00	\$ 0.00
159a	36" x 48", W13-2 (MUTCD) ADVISORY EXIT SPEED (blank)	25	\$ _____	\$ _____	0	\$ 0.00	\$ 0.00	0	\$ 0.00	\$ 0.00	0	\$ 0.00	\$ 0.00

FURNISHING AND DELIVERING TRAFFIC SIGNS  
PROJECT NO. HWY-C-09-23  
ISLANDS OF OAHU, HAWAII, MAUI AND KAUAI  
**PROPOSAL SCHEDULE**

**2. SIGNS, WARNING (REFLECTORIZED, HIGH INTENSITY PRISMATIC) (CONTINUATION):**

BID ITEM NO.	ITEM	OAHU DISTRICT			HAWAII DISTRICT			MAUI DISTRICT			KAUAI DISTRICT		
		EST. YEARLY QTY. (EACH) (A)	UNIT PRICE (B)	AMOUNT (A x B)	EST. YEARLY QTY. (EACH) (C)	UNIT PRICE (D)	AMOUNT (C x D)	EST. YEARLY QTY. (EACH) (E)	UNIT PRICE (F)	AMOUNT (E x F)	EST. YEARLY QTY. (EACH) (G)	UNIT PRICE (H)	AMOUNT (G x H)
160	48" x 60", W13-3 (MUTCD) ADVISORY RAMP SPEED (blank)	40	\$ _____	\$ _____	0	\$ 0.00	\$ 0.00	0	\$ 0.00	\$ 0.00	0	\$ 0.00	\$ 0.00
160a	36" x 48", W13-3 (MUTCD) ADVISORY RAMP SPEED (blank)	25	\$ _____	\$ _____	0	\$ 0.00	\$ 0.00	0	\$ 0.00	\$ 0.00	0	\$ 0.00	\$ 0.00
161	30" x 30", W14-1 (Standard Plan) DEAD END (words)	10	\$ _____	\$ _____	6	\$ _____	\$ _____	0	\$ 0.00	\$ 0.00	5	\$ _____	\$ _____
161a	36" x 36", W14-1-A (Standard Plan) DEAD END (words)	20	\$ _____	\$ _____	0	\$ 0.00	\$ 0.00	0	\$ 0.00	\$ 0.00	0	\$ 0.00	\$ 0.00
161b	36" x 36", W14-2 (MUTCD) NO OUTLET (words)	10	\$ _____	\$ _____	0	\$ 0.00	\$ 0.00	0	\$ 0.00	\$ 0.00	0	\$ 0.00	\$ 0.00
161c	36" x 48" x 48", W14-3 (Standard Plan) NO PASSING ZONE (words)	50	\$ _____	\$ _____	0	\$ 0.00	\$ 0.00	50	\$ _____	\$ _____	0	\$ 0.00	\$ 0.00
162	30" x 30", W8-14 (MUTCD) FALLING ROCKS (words) (Warning Sign)	10	\$ _____	\$ _____	0	\$ 0.00	\$ 0.00	0	\$ 0.00	\$ 0.00	0	\$ 0.00	\$ 0.00
163	36" x 36", W8-14 (MUTCD) FALLING ROCKS (words) (Warning Sign)	10	\$ _____	\$ _____	0	\$ 0.00	\$ 0.00	0	\$ 0.00	\$ 0.00	5	\$ _____	\$ _____
164	36" x 36", W15-4 (modified, MUTCD) WATCH FOR PEDESTRIANS (words) (Fluorescent lime-yellow) <i>Refer to Appendix L.</i>	20	\$ _____	\$ _____	0	\$ 0.00	\$ 0.00	0	\$ 0.00	\$ 0.00	0	\$ 0.00	\$ 0.00

FURNISHING AND DELIVERING TRAFFIC SIGNS  
PROJECT NO. HWY-C-09-23  
ISLANDS OF OAHU, HAWAII, MAUI AND KAUAI  
**PROPOSAL SCHEDULE**

**2. SIGNS, WARNING (REFLECTORIZED, HIGH INTENSITY PRISMATIC) (CONTINUATION):**

BID ITEM NO.	ITEM	OAHU DISTRICT			HAWAII DISTRICT			MAUI DISTRICT			KAUAI DISTRICT		
		EST. YEARLY QTY. (EACH) (A)	UNIT PRICE (B)	AMOUNT (A x B)	EST. YEARLY QTY. (EACH) (C)	UNIT PRICE (D)	AMOUNT (C x D)	EST. YEARLY QTY. (EACH) (E)	UNIT PRICE (F)	AMOUNT (E x F)	EST. YEARLY QTY. (EACH) (G)	UNIT PRICE (H)	AMOUNT (G x H)
165	18" x 24", W16-1P (MUTCD) SHARE THE ROAD (words)	25	\$ _____	\$ _____	6	\$ _____	\$ _____	0	\$ 0.00	\$ 0.00	5	\$ _____	\$ _____
166	24" x 12", W16-7P(L) (MUTCD) DIAGONAL DOWNWARD ARROW LEFT (plaque) [with lime-yellow diamond grade fluorescent reflective sheeting]	300	\$ _____	\$ _____	12	\$ _____	\$ _____	10	\$ _____	\$ _____	0	\$ 0.00	\$ 0.00
167	24" x 12", W16-7P(R) (MUTCD) DIAGONAL DOWNWARD ARROW RIGHT (plaque) [with lime-yellow diamond grade fluorescent reflective sheeting]	100	\$ _____	\$ _____	12	\$ _____	\$ _____	10	\$ _____	\$ _____	0	\$ 0.00	\$ 0.00
168	24" x 12", W16-9p AHEAD (plaque) [with lime- yellow diamond grade fluorescent reflective sheeting]	400	\$ _____	\$ _____	12	\$ _____	\$ _____	0	\$ 0.00	\$ 0.00	0	\$ 0.00	\$ 0.00
169	3" x 12", RM-3, Non-standard, Clearance Marker, Yellow reflector, aluminum, 2 holes, high-intensity grade. <i>Refer to Appendix I1</i>	5,000	\$ _____	\$ _____	0	\$ 0.00	\$ 0.00	2,000	\$ _____	\$ _____	0	\$ 0.00	\$ 0.00
170	12" x 36", OM3-L (MUTCD) OBJECT MARKER, TYPE 3, for bridge marker	300	\$ _____	\$ _____	0	\$ 0.00	\$ 0.00	100	\$ _____	\$ _____	50	\$ _____	\$ _____

FURNISHING AND DELIVERING TRAFFIC SIGNS  
PROJECT NO. HWY-C-09-23  
ISLANDS OF OAHU, HAWAII, MAUI AND KAUAI  
**PROPOSAL SCHEDULE**

**2. SIGNS, WARNING (REFLECTORIZED, HIGH INTENSITY PRISMATIC) (CONTINUATION):**

BID ITEM NO.	ITEM	OAHU DISTRICT			HAWAII DISTRICT			MAUI DISTRICT			KAUAI DISTRICT		
		EST. YEARLY QTY. (EACH) (A)	UNIT PRICE (B)	AMOUNT (A x B)	EST. YEARLY QTY. (EACH) (C)	UNIT PRICE (D)	AMOUNT (C x D)	EST. YEARLY QTY. (EACH) (E)	UNIT PRICE (F)	AMOUNT (E x F)	EST. YEARLY QTY. (EACH) (G)	UNIT PRICE (H)	AMOUNT (G x H)
171	12" x 36", OM3-R (MUTCD) OBJECT MARKER, TYPE 3, for bridge marker	300	\$ _____	\$ _____	0	\$ 0.00	\$ 0.00	100	\$ _____	\$ _____	50	\$ _____	\$ _____
172	12" x 12", OM1-3 (MUTCD) diamond (Yellow reflective, without reflector, high- intensity grade)	200	\$ _____	\$ _____	0	\$ 0.00	\$ 0.00	0	\$ 0.00	\$ 0.00	0	\$ 0.00	\$ 0.00
173	6" x 12", OM2-2V (MUTCD) Object Markers (Yellow Reflective, High-intensity grade, 2 Holes)	1	\$ _____	\$ _____	1	\$ _____	\$ _____	500	\$ _____	\$ _____	1	\$ _____	\$ _____
<b>SUBTOTAL 2</b> (SUM OF BID ITEM NOS. 101 THRU 173 FOR EACH RESPECTIVE DISTRICT)		\$ _____			\$ _____			\$ _____			\$ _____		



FURNISHING AND DELIVERING TRAFFIC SIGNS  
PROJECT NO. HWY-C-09-23  
ISLANDS OF OAHU, HAWAII, MAUI AND KAUAI  
**PROPOSAL SCHEDULE**

**2A. SIGNS, WARNING, ROLL UP, CONSTRUCTION (HIGH INTENSITY PRISMATIC):**

BID ITEM NO.	ITEM	OAHU DISTRICT			HAWAII DISTRICT			MAUI DISTRICT			KAUAI DISTRICT		
		EST. YEARLY QTY. (EACH) (A)	UNIT PRICE (B)	AMOUNT (A x B)	EST. YEARLY QTY. (EACH) (C)	UNIT PRICE (D)	AMOUNT (C x D)	EST. YEARLY QTY. (EACH) (E)	UNIT PRICE (F)	AMOUNT (E x F)	EST. YEARLY QTY. (EACH) (G)	UNIT PRICE (H)	AMOUNT (G x H)
174	48" x 48", CW20-1Ad (Standard Plan) ROAD WORK AHEAD (Roll up Retroreflective Sign <b>with</b> bracing and two flags)	10	\$ _____ —	\$ _____	24	\$ _____	\$ _____	24	\$ _____	\$ _____	0	\$ 0.00	\$ 0.00
175	48" x 48", CW20-7a-A (Standard Plan) FLAGGER (symbol) (Roll Up Retro- reflective Sign <b>with</b> bracing and two flags)	2	\$ _____ —	\$ _____	24	\$ _____	\$ _____	24	\$ _____	\$ _____	0	\$ 0.00	\$ 0.00
176	48" x 48", W3-4 (MUTCD) BE PREPARED TO STOP (words) (Roll Up Retro-reflective Sign <b>with</b> bracing and two flags)	2	\$ _____ —	\$ _____	24	\$ _____	\$ _____	24	\$ _____	\$ _____	0	\$ 0.00	\$ 0.00
177	48" x 48", W21-8 (MUTCD) MOWING AHEAD (words) (Roll Up Retro-reflective Sign <b>with</b> bracing and two flags)	36	\$ _____ —	\$ _____	36	\$ _____	\$ _____	36	\$ _____	\$ _____	0	\$ 0.00	\$ 0.00
178	48" x 48", CW20-5d(L) (Standard Plan) LEFT LANE CLOSED AHEAD (words) with 2-sided Overlay containing the word "LEFT" (Roll Up Retro- reflective Sign <b>with</b> bracing and two flags)	10	\$ _____ —	\$ _____	24	\$ _____	\$ _____	25	\$ _____	\$ _____	0	\$ 0.00	\$ 0.00

FURNISHING AND DELIVERING TRAFFIC SIGNS  
PROJECT NO. HWY-C-09-23  
ISLANDS OF OAHU, HAWAII, MAUI AND KAUAI  
**PROPOSAL SCHEDULE**

**2A. SIGNS, WARNING, ROLL UP, CONSTRUCTION (HIGH INTENSITY PRISMATIC) (CONTINUATION):**

BID ITEM NO.	ITEM	OAHU DISTRICT			HAWAII DISTRICT			MAUI DISTRICT			KAUAI DISTRICT		
		EST. YEARLY QTY. (EACH) (A)	UNIT PRICE (B)	AMOUNT (A x B)	EST. YEARLY QTY. (EACH) (C)	UNIT PRICE (D)	AMOUNT (C x D)	EST. YEARLY QTY. (EACH) (E)	UNIT PRICE (F)	AMOUNT (E x F)	EST. YEARLY QTY. (EACH) (G)	UNIT PRICE (H)	AMOUNT (G x H)
179	SIGN STAND, ALUMINUM (dual Spring for wind resistance designed for 48" roll-up signs, quick release legs for easy set up and take down w/o stooping or bending; adjustable, telescoping legs for stability and mast allows for variable height adjustments)	20	\$ _____	\$ _____	60	\$ _____	\$ _____	100	\$ _____	\$ _____	6	\$ _____	\$ _____
<b>SUBTOTAL 2A</b> (SUM OF BID ITEM NOS. 174 THRU 179 FOR EACH RESPECTIVE DISTRICT)		\$ _____			\$ _____			\$ _____			\$ _____		

FURNISHING AND DELIVERING TRAFFIC SIGNS  
PROJECT NO. HWY-C-09-23  
ISLANDS OF OAHU, HAWAII, MAUI AND KAUAI  
**PROPOSAL SCHEDULE**

**3. SIGNS, DESTINATION, AND AUXILIARY; MARKERS, ROUTE, DIRECTIONAL (REFLECTORIZED, HIGH INTENSITY PRISMATIC):**

BID ITEM NO.	ITEM	OAHU DISTRICT			HAWAII DISTRICT			MAUI DISTRICT			KAUAI DISTRICT		
		EST. YEARLY QTY. (EACH) (A)	UNIT PRICE (B)	AMOUNT (A x B)	EST. YEARLY QTY. (EACH) (C)	UNIT PRICE (D)	AMOUNT (C x D)	EST. YEARLY QTY. (EACH) (E)	UNIT PRICE (F)	AMOUNT (E x F)	EST. YEARLY QTY. (EACH) (G)	UNIT PRICE (H)	AMOUNT (G x H)
180	48" x 24". *D14-3 (modified, MUTCD) Non-standard, •ADOPT A HIGHWAY LITTER CONTROL NEXT 2 MILES [words] Refer to Appendix J, of the Appendices	50	\$ _____	\$ _____	0	\$ 0.00	\$ 0.00	0	\$ 0.00	\$ 0.00	0	\$ 0.00	\$ 0.00
181	24" x 18" D11-1 BIKE ROUTE (bicycle symbol and words *BIKE ROUTE*)	100	\$ _____	\$ _____	0	\$ 0.00	\$ 0.00	50	\$ _____	\$ _____	5	\$ _____	\$ _____
182	24" x 24" M1-1 (blank) (MUTCD) INTERSTATE ROUTE (blank)	50	\$ _____	\$ _____	0	\$ 0.00	\$ 0.00	25	\$ _____	\$ _____	0	\$ 0.00	\$ 0.00
183	24" x 24" M1-6 State Route Marker (blank), Refer to Standard Plans TE-11 & 12, Appendix A of the Appendices	100	\$ _____	\$ _____	36	\$ _____	\$ _____	25	\$ _____	\$ _____	0	\$ 0.00	\$ 0.00
184	24" x 12" IM3-1 NORTH (blue with white), Refer to Standard Plans TE-11, Appendix A of the Appendices	25	\$ _____	\$ _____	0	\$ 0.00	\$ 0.00	0	\$ 0.00	\$ 0.00	0	\$ 0.00	\$ 0.00

FURNISHING AND DELIVERING TRAFFIC SIGNS  
PROJECT NO. HWY-C-09-23  
ISLANDS OF OAHU, HAWAII, MAUI AND KAUAI  
PROPOSAL SCHEDULE

**3. SIGNS, DESTINATION, AND AUXILIARY; MARKERS, ROUTE, DIRECTIONAL (REFLECTORIZED, HIGH INTENSITY PRISMATIC) (CONTINUATION):**

BID ITEM NO.	ITEM	OAHU DISTRICT			HAWAII DISTRICT			MAUI DISTRICT			KAUAI DISTRICT		
		EST. YEARLY QTY. (EACH) (A)	UNIT PRICE (B)	AMOUNT (A x B)	EST. YEARLY QTY. (EACH) (C)	UNIT PRICE (D)	AMOUNT (C x D)	EST. YEARLY QTY. (EACH) (E)	UNIT PRICE (F)	AMOUNT (E x F)	EST. YEARLY QTY. (EACH) (G)	UNIT PRICE (H)	AMOUNT (G x H)
185	24" x12" M3-1 NORTH (white with black), Refer to Standard Plans TE-11, Appendix A of the Appendices	50	\$ _____	\$ _____	0	\$ 0.00	\$ 0.00	0	\$ 0.00	\$ 0.00	4	\$ _____	\$ _____
186	30" x15" IM3-1 NORTH (blue with white), Refer to Standard Plans TE-11, Appendix A of the Appendices	25	\$ _____	\$ _____	0	\$ 0.00	\$ 0.00	0	\$ 0.00	\$ 0.00	0	\$ 0.00	\$ 0.00
187	30" x15" M3-1 NORTH (white with black), Refer to Standard Plans TE-11, Appendix A of the Appendices	20	\$ _____	\$ _____	0	\$ 0.00	\$ 0.00	0	\$ 0.00	\$ 0.00	0	\$ 0.00	\$ 0.00
188	30" x 15" IM3-2 EAST (blue with black), Refer to Standard Plans TE-11, Appendix A of the Appendices	25	\$ _____	\$ _____	0	\$ 0.00	\$ 0.00	0	\$ 0.00	\$ 0.00	0	\$ 0.00	\$ 0.00
189	24" x 12" M3-2 EAST (white with black), Refer to Standard Plans TE-11, Appendix A of the Appendices	25	\$ _____	\$ _____	0	\$ 0.00	\$ 0.00	0	\$ 0.00	\$ 0.00	4	\$ _____	\$ _____
190	30" x 15" M3-2 EAST (white with black), Refer to Standard Plans TE-11, Appendix A of the Appendices	25	\$ _____	\$ _____	0	\$ 0.00	\$ 0.00	0	\$ 0.00	\$ 0.00	0	\$ 0.00	\$ 0.00
191	24" x 12" IM3-3 SOUTH (blue with white), Refer to Standard Plans TE-11, Appendix A of the Appendices	50	\$ _____	\$ _____	0	\$ 0.00	\$ 0.00	0	\$ 0.00	\$ 0.00	4	\$ _____	\$ _____

FURNISHING AND DELIVERING TRAFFIC SIGNS  
PROJECT NO. HWY-C-09-23  
ISLANDS OF OAHU, HAWAII, MAUI AND KAUAI  
**PROPOSAL SCHEDULE**

**3. SIGNS, DESTINATION, AND AUXILIARY; MARKERS, ROUTE, DIRECTIONAL (REFLECTORIZED, HIGH INTENSITY PRISMATIC) (CONTINUATION):**

BID ITEM NO.	ITEM	OAHU DISTRICT			HAWAII DISTRICT			MAUI DISTRICT			KAUAI DISTRICT		
		EST. YEARLY QTY. (EACH) (A)	UNIT PRICE (B)	AMOUNT (A x B)	EST. YEARLY QTY. (EACH) (C)	UNIT PRICE (D)	AMOUNT (C x D)	EST. YEARLY QTY. (EACH) (E)	UNIT PRICE (F)	AMOUNT (E x F)	EST. YEARLY QTY. (EACH) (G)	UNIT PRICE (H)	AMOUNT (G x H)
192	24" x 12" M3-3 SOUTH (white with black), Refer to Standard Plans TE-11, Appendix A of the Appendices	25	\$ _____	\$ _____	0	\$ 0.00	\$ 0.00	0	\$ 0.00	\$ 0.00	4	\$ _____	\$ _____
193	30" x 15" IM3-3 SOUTH (blue with white), Refer to Standard Plans TE-11, Appendix A of the Appendices	20	\$ _____	\$ _____	0	\$ 0.00	\$ 0.00	0	\$ 0.00	\$ 0.00	0	\$ 0.00	\$ 0.00
194	30" x 15" M3-3 SOUTH (white with black), Refer to Standard Plans TE-11, Appendix A of the Appendices	50	\$ _____	\$ _____	0	\$ 0.00	\$ 0.00	0	\$ 0.00	\$ 0.00	0	\$ 0.00	\$ 0.00
195	24" x 12" IM3-4 WEST (blue with white), Refer to Standard Plans TE-11, Appendix A of the Appendices	25	\$ _____	\$ _____	0	\$ 0.00	\$ 0.00	0	\$ 0.00	\$ 0.00	0	\$ 0.00	\$ 0.00
196	30" x 15" IM3-4 WEST (blue with white), Refer to Standard Plans TE-11, Appendix A of the Appendices	50	\$ _____	\$ _____	0	\$ 0.00	\$ 0.00	0	\$ 0.00	\$ 0.00	0	\$ 0.00	\$ 0.00
197	30" x 15" M3-4 WEST (white with black), Refer to Standard Plans TE-11, Appendix A of the Appendices	25	\$ _____	\$ _____	0	\$ 0.00	\$ 0.00	0	\$ 0.00	\$ 0.00	0	\$ 0.00	\$ 0.00

FURNISHING AND DELIVERING TRAFFIC SIGNS  
PROJECT NO. HWY-C-09-23  
ISLANDS OF OAHU, HAWAII, MAUI AND KAUAI  
**PROPOSAL SCHEDULE**

**3. SIGNS, DESTINATION, AND AUXILIARY; MARKERS, ROUTE, DIRECTIONAL (REFLECTORIZED, HIGH INTENSITY PRISMATIC) (CONTINUATION):**

BID ITEM NO.	ITEM	OAHU DISTRICT			HAWAII DISTRICT			MAUI DISTRICT			KAUAI DISTRICT		
		EST. YEARLY QTY. (EACH) (A)	UNIT PRICE (B)	AMOUNT (A x B)	EST. YEARLY QTY. (EACH) (C)	UNIT PRICE (D)	AMOUNT (C x D)	EST. YEARLY QTY. (EACH) (E)	UNIT PRICE (F)	AMOUNT (E x F)	EST. YEARLY QTY. (EACH) (G)	UNIT PRICE (H)	AMOUNT (G x H)
198	24" x 12" IM4-5 TO (blue with white), Refer to Standard Plans TE-11, Appendix A of the Appendices	20	\$ _____	\$ _____	0	\$ 0.00	\$ 0.00	0	\$ 0.00	\$ 0.00	0	\$ 0.00	\$ 0.00
199	30" x 15" IM4-5 TO (blue with white), Refer to Standard Plans TE-11, Appendix A of the Appendices	25	\$ _____	\$ _____	0	\$ 0.00	\$ 0.00	0	\$ 0.00	\$ 0.00	0	\$ 0.00	\$ 0.00
200	24" x 12" M4-5 TO (white with black), Refer to Standard Plans TE-11, Appendix A of the Appendices	20	\$ _____	\$ _____	0	\$ 0.00	\$ 0.00	0	\$ 0.00	\$ 0.00	0	\$ 0.00	\$ 0.00
201	21" x 15" IM6-1(L) ARROW AUXILIARY, LEFT (blue with white), Refer to Standard Plans TE-11, Appendix A of the Appendices	25	\$ _____	\$ _____	0	\$ 0.00	\$ 0.00	0	\$ 0.00	\$ 0.00	0	\$ 0.00	\$ 0.00
202	30" x 21" IM6-1(L) ARROW AUXILIARY, LEFT (blue with white) or (white with black), Refer to Standard Plans TE-11, Appendix A of the Appendices	25	\$ _____	\$ _____	0	\$ 0.00	\$ 0.00	0	\$ 0.00	\$ 0.00	0	\$ 0.00	\$ 0.00
203	21" x 15" M6-1(L) ARROW AUXILIARY, LEFT (white with black), Refer to Standard Plans TE-11, Appendix A of the Appendices	25	\$ _____	\$ _____	10	\$ _____	\$ _____	0	\$ 0.00	\$ 0.00	0	\$ 0.00	\$ 0.00

FURNISHING AND DELIVERING TRAFFIC SIGNS  
PROJECT NO. HWY-C-09-23  
ISLANDS OF OAHU, HAWAII, MAUI AND KAUAI  
**PROPOSAL SCHEDULE**

**3. SIGNS, DESTINATION, AND AUXILIARY; MARKERS, ROUTE, DIRECTIONAL (REFLECTORIZED, HIGH INTENSITY PRISMATIC) (CONTINUATION):**

BID ITEM NO.	ITEM	OAHU DISTRICT			HAWAII DISTRICT			MAUI DISTRICT			KAUAI DISTRICT		
		EST. YEARLY QTY. (EACH) (A)	UNIT PRICE (B)	AMOUNT (A x B)	EST. YEARLY QTY. (EACH) (C)	UNIT PRICE (D)	AMOUNT (C x D)	EST. YEARLY QTY. (EACH) (E)	UNIT PRICE (F)	AMOUNT (E x F)	EST. YEARLY QTY. (EACH) (G)	UNIT PRICE (H)	AMOUNT (G x H)
204	21" x 15" IM6-2(L) DIAGONAL ARROW AUXILIARY, LEFT (blue with white), Refer to Standard Plans TE-11, Appendix A of the Appendices	25	\$ _____	\$ _____	0	\$ 0.00	\$ 0.00	0	\$ 0.00	\$ 0.00	0	\$ 0.00	\$ 0.00
205	21" x 15" IM6-2(R) DIAGONAL ARROW AUXILIARY, RIGHT (blue with white), Refer to Standard Plans TE-11, Appendix A of the Appendices	25	\$ _____	\$ _____	0	\$ 0.00	\$ 0.00	0	\$ 0.00	\$ 0.00	0	\$ 0.00	\$ 0.00
206	21" x 15" M6-2(L) DIAGONAL ARROW AUXILIARY, LEFT (white with black), Refer to Standard Plans TE-11, Appendix A of the Appendices	25	\$ _____	\$ _____	6	\$ _____	\$ _____	0	\$ 0.00	\$ 0.00	5	\$ _____	\$ _____
207	21" x 15" M6-2(R) DIAGONAL ARROW AUXILIARY, RIGHT (white with black), Refer to Standard Plans TE-11, Appendix A of the Appendices	25	\$ _____	\$ _____	6	\$ _____	\$ _____	0	\$ 0.00	\$ 0.00	0	\$ 0.00	\$ 0.00
208	21" x 15" IM6-3 STRAIGHT ARROW AUXILIARY (blue with white), Refer to Standard Plans TE-11, Appendix A of the Appendices	25	\$ _____	\$ _____	0	\$ 0.00	\$ 0.00	0	\$ 0.00	\$ 0.00	0	\$ 0.00	\$ 0.00
209	21" x 15" M6-3 STRAIGHT ARROW AUXILIARY (white with black), Refer to Standard Plans TE-11, Appendix A of the Appendices	25	\$ _____	\$ _____	6	\$ _____	\$ _____	0	\$ 0.00	\$ 0.00	5	\$ _____	\$ _____

FURNISHING AND DELIVERING TRAFFIC SIGNS  
PROJECT NO. HWY-C-09-23  
ISLANDS OF OAHU, HAWAII, MAUI AND KAUAI  
**PROPOSAL SCHEDULE**

**3. SIGNS, DESTINATION, AND AUXILIARY; MARKERS, ROUTE, DIRECTIONAL (REFLECTORIZED, HIGH INTENSITY PRISMATIC) (CONTINUATION):**

BID ITEM NO.	ITEM	OAHU DISTRICT			HAWAII DISTRICT			MAUI DISTRICT			KAUAI DISTRICT		
		EST. YEARLY QTY. (EACH) (A)	UNIT PRICE (B)	AMOUNT (A x B)	EST. YEARLY QTY. (EACH) (C)	UNIT PRICE (D)	AMOUNT (C x D)	EST. YEARLY QTY. (EACH) (E)	UNIT PRICE (F)	AMOUNT (E x F)	EST. YEARLY QTY. (EACH) (G)	UNIT PRICE (H)	AMOUNT (G x H)
210	24" x 24" STOP (R1-1)/SLOW (W20-8), aluminum paddle, retro reflectorized, (reads STOP on one side and slow on the other side) w/ 2 pre-drilled holes (or handle mounting. Signs include: 72" long, 1" diameter wooden handles and required mounting bolts/screws.	10	\$ _____	\$ _____	0	\$ 0.00	\$ 0.00	24	\$ _____	\$ _____	4	\$ _____	\$ _____
<b>SUBTOTAL 3</b> (SUM OF BID ITEM NOS. 180 THRU 210 FOR EACH RESPECTIVE DISTRICT)		\$ _____			\$ _____			\$ _____			\$ _____		



FURNISHING AND DELIVERING TRAFFIC SIGNS  
PROJECT NO. HWY-C-09-23  
ISLANDS OF OAHU, HAWAII, MAUI AND KAUAI  
**PROPOSAL SCHEDULE**

**4. SIGNS, SCHOOL (DIMOND GRADE FLUORESCENT):**

BID ITEM NO.	ITEM	OAHU DISTRICT			HAWAII DISTRICT			MAUI DISTRICT			KAUAI DISTRICT		
		EST. YEARLY QTY. (EACH) (A)	UNIT PRICE (B)	AMOUNT (A x B)	EST. YEARLY QTY. (EACH) (C)	UNIT PRICE (D)	AMOUNT (C x D)	EST. YEARLY QTY. (EACH) (E)	UNIT PRICE (F)	AMOUNT (E x F)	EST. YEARLY QTY. (EACH) (G)	UNIT PRICE (H)	AMOUNT (G x H)
211	36" x 36" S1-1, (MUTCD) SCHOOL (symbol) [with lime- green diamond grade fluorescent reflective sheeting]	100	\$ _____	\$ _____	24	\$ _____	\$ _____	48	\$ _____	\$ _____	4	\$ _____	\$ _____
212	24" x 18" S2-1P, (modified MUTCD), SCHOOL XING [with lime-green diamond grade fluorescent reflective sheeting] <i>Refer to Appendix M</i>	25	\$ _____	\$ _____	8	\$ _____	\$ _____	10	\$ _____	\$ _____	0	\$ 0.00	\$ 0.00
213	24" x 8" S4-3, (MUTCD) SCHOOL (PLAQUE)	24	\$ _____	\$ _____	8	\$ _____	\$ _____	24	\$ _____	\$ _____	4	\$ _____	\$ _____
<b>SUBTOTAL 4</b> (SUM OF BID ITEM NOS. 211 THRU 213 FOR EACH RESPECTIVE DISTRICT)		\$ _____			\$ _____			\$ _____			\$ _____		

FURNISHING AND DELIVERING TRAFFIC SIGNS  
PROJECT NO. HWY-C-09-23  
ISLANDS OF OAHU, HAWAII, MAUI AND KAUAI  
**PROPOSAL SCHEDULE**

**5. SIGNS, TRAFFIC, ALUMINUM BLANKS:**

BID ITEM NO.	ITEM	OAHU DISTRICT			HAWAII DISTRICT			MAUI DISTRICT			KAUAI DISTRICT		
		EST. YEARLY QTY. (EACH) (A)	UNIT PRICE (B)	AMOUNT (A x B)	EST. YEARLY QTY. (EACH) (C)	UNIT PRICE (D)	AMOUNT (C x D)	EST. YEARLY QTY. (EACH) (E)	UNIT PRICE (F)	AMOUNT (E x F)	EST. YEARLY QTY. (EACH) (G)	UNIT PRICE (H)	AMOUNT (G x H)
214	9" x 24" Street name plate with crown, no holes	5	\$ _____	\$ _____	0	\$ 0.00	\$ 0.00	200	\$ _____	\$ _____	20	\$ _____	\$ _____
215	9" x 30" Street name plate with crown, no holes	2	\$ _____	\$ _____	0	\$ 0.00	\$ 0.00	50	\$ _____	\$ _____	20	\$ _____	\$ _____
216	9" x 36" Street name plate with crown, no holes	2	\$ _____	\$ _____	0	\$ 0.00	\$ 0.00	50	\$ _____	\$ _____	0	\$ 0.00	\$ 0.00
217	10" x 7" Rounded corners w/ two (2) holes, 3/8" diameter	2	\$ _____	\$ _____	0	\$ 0.00	\$ 0.00	50	\$ _____	\$ _____	0	\$ 0.00	\$ 0.00
218	10" x 27" Rounded corners w/ two (2) holes, 3/8" diameter	100	\$ _____	\$ _____	20	\$ _____	\$ _____	100	\$ _____	\$ _____	20	\$ _____	\$ _____
219	10" x 18" Rounded corners w/ two (2) holes, 3/8" diameter	100	\$ _____	\$ _____	0	\$ 0.00	\$ 0.00	20	\$ _____	\$ _____	0	\$ 0.00	\$ 0.00
220	12" x 18" Rounded corners, no holes	2	\$ _____	\$ _____	0	\$ 0.00	\$ 0.00	0	\$ 0.00	\$ 0.00	20	\$ _____	\$ _____
221	12" x 18" Rounded corners w/ two (2) holes, 3/8" diameter	200	\$ _____	\$ _____	0	\$ 0.00	\$ 0.00	100	\$ _____	\$ _____	150	\$ _____	\$ _____

FURNISHING AND DELIVERING TRAFFIC SIGNS  
PROJECT NO. HWY-C-09-23  
ISLANDS OF OAHU, HAWAII, MAUI AND KAUAI  
**PROPOSAL SCHEDULE**

**5. SIGNS, TRAFFIC, ALUMINUM BLANKS** (CONTINUATION):

BID ITEM NO.	ITEM	OAHU DISTRICT			HAWAII DISTRICT			MAUI DISTRICT			KAUAI DISTRICT		
		EST. YEARLY QTY. (EACH) (A)	UNIT PRICE (B)	AMOUNT (A x B)	EST. YEARLY QTY. (EACH) (C)	UNIT PRICE (D)	AMOUNT (C x D)	EST. YEARLY QTY. (EACH) (E)	UNIT PRICE (F)	AMOUNT (E x F)	EST. YEARLY QTY. (EACH) (G)	UNIT PRICE (H)	AMOUNT (G x H)
222	12" x 48" Rounded corners w/ two (2) holes, 3/8" diameter	2	\$ _____	\$ _____	0	\$ 0.00	\$ 0.00	100	\$ _____	\$ _____	25	\$ _____	\$ _____
223	18" x 24" Rounded corners w/ two (2) holes, 3/8" diameter	2	\$ _____	\$ _____	0	\$ 0.00	\$ 0.00	75	\$ _____	\$ _____	0	\$ 0.00	\$ 0.00
224	18" x 96" Square corners and no holes	100	\$ _____	\$ _____	0	\$ 0.00	\$ 0.00	20	\$ _____	\$ _____	10	\$ _____	\$ _____
225	24" x 24" Rounded corners w/ two (2) holes, 3/8" diameter	20	\$ _____	\$ _____	20	\$ _____	\$ _____	100	\$ _____	\$ _____	25	\$ _____	\$ _____
226	24" x 30" Rounded corners w/ two (2) holes, 3/8" diameter	100	\$ _____	\$ _____	0	\$ 0.00	\$ 0.00	100	\$ _____	\$ _____	25	\$ _____	\$ _____
227	24" x 48" Rounded corners w/ four (4) holes, 3/8" diameter	150	\$ _____	\$ _____	0	\$ 0.00	\$ 0.00	40	\$ _____	\$ _____	25	\$ _____	\$ _____
228	24" x 72" Square corners and no holes	50	\$ _____	\$ _____	0	\$ 0.00	\$ 0.00	0	\$ 0.00	\$ 0.00	25	\$ _____	\$ _____
229	24" x 96" Rounded corners w/ four (4) holes, 3/8" diameter	25	\$ _____	\$ _____	0	\$ 0.00	\$ 0.00	10	\$ _____	\$ _____	25	\$ _____	\$ _____

FURNISHING AND DELIVERING TRAFFIC SIGNS  
PROJECT NO. HWY-C-09-23  
ISLANDS OF OAHU, HAWAII, MAUI AND KAUAI  
**PROPOSAL SCHEDULE**

**5. SIGNS, TRAFFIC, ALUMINUM BLANKS** (CONTINUATION):

BID ITEM NO.	ITEM	OAHU DISTRICT			HAWAII DISTRICT			MAUI DISTRICT			KAUAI DISTRICT		
		EST. YEARLY QTY. (EACH) (A)	UNIT PRICE (B)	AMOUNT (A x B)	EST. YEARLY QTY. (EACH) (C)	UNIT PRICE (D)	AMOUNT (C x D)	EST. YEARLY QTY. (EACH) (E)	UNIT PRICE (F)	AMOUNT (E x F)	EST. YEARLY QTY. (EACH) (G)	UNIT PRICE (H)	AMOUNT (G x H)
230	30" x 30" Rounded corners w/ two (2) holes, 3/8" diameter	50	\$ _____	\$ _____	20	\$ _____	\$ _____	100	\$ _____	\$ _____	40	\$ _____	\$ _____
231	30" x 36" Rounded corners w/ two (2) holes, 3/8" diameter	20	\$ _____	\$ _____	0	\$ 0.00	\$ 0.00	50	\$ _____	\$ _____	20	\$ _____	\$ _____
232	36" x 36" Rounded corners w/ two (2) holes, 3/8" diameter	50	\$ _____	\$ _____	20	\$ _____	\$ _____	100	\$ _____	\$ _____	20	\$ _____	\$ _____
233	30" x 48" Rounded corners w/ two (2) holes, 3/8" diameter	25	\$ _____	\$ _____	0	\$ 0.00	\$ 0.00	50	\$ _____	\$ _____	30	\$ _____	\$ _____
234	36" x 48" Rounded comers w/ two (2) holes, 3/8" diameter	2	\$ _____	\$ _____	0	\$ 0.00	\$ 0.00	20	\$ _____	\$ _____	30	\$ _____	\$ _____
235	36" x 36" Rounded corners w/ four (4) holes, 3/8" diameter	50	\$ _____	\$ _____	0	\$ 0.00	\$ 0.00	100	\$ _____	\$ _____	30	\$ _____	\$ _____
236	36" x 48" Rounded corners w/ four (4) holes, 3/8" diameter	20	\$ _____	\$ _____	0	\$ 0.00	\$ 0.00	50	\$ _____	\$ _____	10	\$ _____	\$ _____

FURNISHING AND DELIVERING TRAFFIC SIGNS  
PROJECT NO. HWY-C-09-23  
ISLANDS OF OAHU, HAWAII, MAUI AND KAUAI  
**PROPOSAL SCHEDULE**

**5. SIGNS, TRAFFIC, ALUMINUM BLANKS** (CONTINUATION):

BID ITEM NO.	ITEM	OAHU DISTRICT			HAWAII DISTRICT			MAUI DISTRICT			KAUAI DISTRICT		
		EST. YEARLY QTY. (EACH) (A)	UNIT PRICE (B)	AMOUNT (A x B)	EST. YEARLY QTY. (EACH) (C)	UNIT PRICE (D)	AMOUNT (C x D)	EST. YEARLY QTY. (EACH) (E)	UNIT PRICE (F)	AMOUNT (E x F)	EST. YEARLY QTY. (EACH) (G)	UNIT PRICE (H)	AMOUNT (G x H)
237	36" x 72" Rounded corners w/ four (4) holes, 3/8" diameter	25	\$ _____	\$ _____	0	\$ 0.00	\$ 0.00	25	\$ _____	\$ _____	0	\$ 0.00	\$ 0.00
238	36" x 72" Square corners and no holes	100	\$ _____	\$ _____	0	\$ 0.00	\$ 0.00	0	\$ 0.00	\$ 0.00	20	\$ _____	\$ _____
239	36" x 72" Rounded corners w/ four (4) holes, 3/8" diameter	100	\$ _____	\$ _____	0	\$ 0.00	\$ 0.00	10	\$ _____	\$ _____	20	\$ _____	\$ _____
240	24" x 96" Rounded corners w/ four (4) holes, 3/8" diameter	2	\$ _____	\$ _____	0	\$ 0.00	\$ 0.00	20	\$ _____	\$ _____	20	\$ _____	\$ _____
241	36" x 96" Rounded corners w/ four (4) holes, 3/8" diameter	100	\$ _____	\$ _____	0	\$ 0.00	\$ 0.00	10	\$ _____	\$ _____	20	\$ _____	\$ _____
242	48" x 12" Rounded corners w/ four (4) holes, 3/8" diameter (for Adopt-A Highway sign)	200	\$ _____	\$ _____	40	\$ _____	\$ _____	50	\$ _____	\$ _____	60	\$ _____	\$ _____
243	48" x 24" Rounded corners w/ four (4) holes, 3/8" diameter (for Adopt-A Highway sign)	50	\$ _____	\$ _____	40	\$ _____	\$ _____	100	\$ _____	\$ _____	30	\$ _____	\$ _____

FURNISHING AND DELIVERING TRAFFIC SIGNS  
PROJECT NO. HWY-C-09-23  
ISLANDS OF OAHU, HAWAII, MAUI AND KAUAI  
**PROPOSAL SCHEDULE**

**5. SIGNS, TRAFFIC, ALUMINUM BLANKS (CONTINUATION):**

BID ITEM NO.	ITEM	OAHU DISTRICT			HAWAII DISTRICT			MAUI DISTRICT			KAUAI DISTRICT		
		EST. YEARLY QTY. (EACH) (A)	UNIT PRICE (B)	AMOUNT (A x B)	EST. YEARLY QTY. (EACH) (C)	UNIT PRICE (D)	AMOUNT (C x D)	EST. YEARLY QTY. (EACH) (E)	UNIT PRICE (F)	AMOUNT (E x F)	EST. YEARLY QTY. (EACH) (G)	UNIT PRICE (H)	AMOUNT (G x H)
244	48" x 48" Rounded corners w/ four (4) holes, 3/8" diameter	20	\$ _____	\$ _____	0	\$ 0.00	\$ 0.00	50	\$ _____	\$ _____	20	\$ _____	\$ _____
245	48" x 144" Rounded corners w/ four (4) holes, 3/8" diameter	2	\$ _____	\$ _____	0	\$ 0.00	\$ 0.00	0	\$ 0.00	\$ 0.00	25	\$ _____	\$ _____
246	48" x 144" Square corners and no holes	100	\$ _____	\$ _____	0	\$ 0.00	\$ 0.00	0	\$ 0.00	\$ 0.00	0	\$ 0.00	\$ 0.00
247	24" x 72" Rounded corners w/ four (4) holes, 3/8" diameter	1	\$ _____	\$ _____	0	\$ 0.00	\$ 0.00	5	\$ _____	\$ _____	20	\$ _____	\$ _____
248	18" x 96" Rounded corners, no holes	1	\$ _____	\$ _____	0	\$ 0.00	\$ 0.00	5	\$ _____	\$ _____	30	\$ _____	\$ _____
249	48" x 96" Rounded corners, no holes	10	\$ _____	\$ _____	0	\$ 0.00	\$ 0.00	20	\$ _____	\$ _____	30	\$ _____	\$ _____
250	48" x 96" Square corners and no holes	50	\$ _____	\$ _____	0	\$ 0.00	\$ 0.00	0	\$ 0.00	\$ 0.00	10	\$ _____	\$ _____

FURNISHING AND DELIVERING TRAFFIC SIGNS  
PROJECT NO. HWY-C-09-23  
ISLANDS OF OAHU, HAWAII, MAUI AND KAUAI  
**PROPOSAL SCHEDULE**

**5. SIGNS, TRAFFIC, ALUMINUM BLANKS** (CONTINUATION):

BID ITEM NO.	ITEM	OAHU DISTRICT			HAWAII DISTRICT			MAUI DISTRICT			KAUAI DISTRICT		
		EST. YEARLY QTY. (EACH) (A)	UNIT PRICE (B)	AMOUNT (A x B)	EST. YEARLY QTY. (EACH) (C)	UNIT PRICE (D)	AMOUNT (C x D)	EST. YEARLY QTY. (EACH) (E)	UNIT PRICE (F)	AMOUNT (E x F)	EST. YEARLY QTY. (EACH) (G)	UNIT PRICE (H)	AMOUNT (G x H)
251	48" x 144" Rounded corners w/ four (4) holes, 3/8" diameter	25	\$ _____	\$ _____	0	\$ 0.00	\$ 0.00	0	\$ 0.00	\$ 0.00	10	\$ _____	\$ _____
252	6" x 120" (with green reflective sheeting)	1	\$ _____	\$ _____	6	\$ _____	\$ _____	12	\$ _____	\$ _____	0	\$ 0.00	\$ 0.00
253	12" x 120" (with green reflective sheeting)	1	\$ _____	\$ _____	0	\$ 0.00	\$ 0.00	24	\$ _____	\$ _____	0	\$ 0.00	\$ 0.00
254	6" x 12" Rounded corners w/ two (2) holes, 3/8" diameter [with white high intensity reflective sheeting]	500	\$ _____	\$ _____	0	\$ 0.00	\$ 0.00	0	\$ 0.00	\$ 0.00	0	\$ 0.00	\$ 0.00
255	24" x 24", RS-142a AHUPUA'A Symbol (brown with white letter and borders, DG sheeting) (modified, MUTCD) Non- standard <i>Refer to Appendix K</i>  24" x 12", Educational Plaque is incidental to RS-142a sign <i>Refer to Appendix K</i>	50	\$ _____	\$ _____	1	\$ _____	\$ _____	1	\$ _____	\$ _____	1	\$ _____	\$ _____
<b>SUBTOTAL 5</b> (SUM OF BID ITEM NOS. 214 THRU 256 FOR EACH RESPECTIVE DISTRICT)		\$ _____			\$ _____			\$ _____			\$ _____		

FURNISHING AND DELIVERING TRAFFIC SIGNS  
 PROJECT NO. HWY-C-09-23  
 ISLANDS OF OAHU, HAWAII, MAUI AND KAUAI  
**PROPOSAL SCHEDULE**

BID SUMMARY

	OAHU DISTRICT	HAWAII DISTRICT	MAUI DISTRICT	KAUAI DISTRICT
SUBTOTAL 1	\$ _____	\$ _____	\$ _____	\$ _____
SUBTOTAL 2	\$ _____	\$ _____	\$ _____	\$ _____
SUBTOTAL 2A	\$ _____	\$ _____	\$ _____	\$ _____
SUBTOTAL 3	\$ _____	\$ _____	\$ _____	\$ _____
SUBTOTAL 4	\$ _____	\$ _____	\$ _____	\$ _____
SUBTOTAL 5	\$ _____	\$ _____	\$ _____	\$ _____
TOTAL of each district (Sum of 1 thru 5)	\$ _____	\$ _____	\$ _____	\$ _____

<b>TOTAL AMOUNT FOR COMPARISON OF BIDS</b> .....	\$ _____
Sum of all districts (Oahu + Hawaii + Maui + Kauai District)	

**NOTES:**

1. Bids shall include all Federal, State, County and other applicable taxes and fees.
2. The TOTAL AMOUNT FOR COMPARISON OF BIDS will be used to determine the lowest responsible bidder.
3. Bidder must complete all unit price and amounts. Failure to do so shall be grounds for rejection of bid.
4. In case of a discrepancy occurs between unit bid price and the bid price, the unit bid price shall govern.
5. The Bidder shall make no changes to the items. Bid submitted with changes to the item(s) are considered rejectable bid
6. **By submitting a proposal, the bidder acknowledges he has read and understands all the provisions of the Special Provisions, Specifications and is fully aware of all the conditions to be encountered in performing the work.**



FURNISHING AND DELIVERING TRAFFIC SIGNS  
PROJECT NO. HWY-C-09-23  
ISLANDS OF OAHU, HAWAII, MAUI AND KAUAI  
**PROPOSAL SCHEDULE**

**NOTES CONTINUED:**

7. **Bidders shall submit and upload the complete proposal to HIePRO prior to the bid opening date and time. Proposals received after said due date and time shall not be considered.** Original (wet ink, hard copy) proposal documents are not required to be submitted. **Contract award shall be based on evaluation of proposals submitted and uploaded to HIePRO. Any additional support documents explicitly designated as confidential and/or proprietary shall be uploaded as a separate file to HIePRO. Do not include confidential and/or proprietary documents with the proposal. The record of each bidder and respective bid shall be open to public inspection.**

**FAILURE TO UPLOAD THE COMPLETE PROPOSAL TO HIePRO SHALL BE GROUNDS FOR REJECTION OF THE BID.**

If there is a conflict between the specification document and the HIePRO solicitation, the specifications shall govern and control, unless otherwise specified.

8. The Manual on Uniform Traffic Control Devices (MUTCD) Edition 2009, Revision III <sup>\*1</sup>, the Standard Highway Signs 2004 Edition, 2012 Supplement <sup>\*2</sup> and the Standard Plan (Appendix A) shall be utilized when bid items **do not** specify a specific Appendix or Standard Plan. If sign can't be found in either of the three places, please reference the Appendix for non-standard signs. The bid item should specify if a specific reference should be utilized.

Referenced link at the following website:

1\* - [https://mutcd.fhwa.dot.gov/kno\\_2009r1r2r3.htm](https://mutcd.fhwa.dot.gov/kno_2009r1r2r3.htm)

2\* - [https://mutcd.fhwa.dot.gov/ser-shs\\_millennium.htm](https://mutcd.fhwa.dot.gov/ser-shs_millennium.htm)

STATE OF HAWAII  
DEPARTMENT OF TRANSPORTATION  
HONOLULU, HAWAII

FORMS

Contents:

Sample Contract

Certificate of Performance Services

## C O N T R A C T

THIS AGREEMENT, made this day \_\_\_\_\_, by and between the STATE OF HAWAII, by its Director of Transportation, hereinafter referred to as "STATE", and «CONTRACTOR», «STATE OF INCORPORATION», whose business/post office address is «ADDRESS» hereinafter referred to as "CONTRACTOR";

WITNESSETH: That for and in consideration of the payments hereinafter mentioned, the CONTRACTOR hereby covenants and agrees with the STATE to furnish, perform and/or deliver and pay for all labor, supplies, materials, equipment and services called for in such quantities as requested by the STATE, and the STATE agrees to pay for same at the unit prices set forth in the attached proposal schedule for the project entitled:

“«PROJECT NAME AND NO»”

in lawful money, but not more than such sum as is actually earned according to STATE's determination of the actual quantities of work performed and materials furnished by CONTRACTOR at the unit prices set forth in said attached proposal schedule, for which payment shall be made by the STATE in accordance with Section 9.4 of the Special Provisions during the term of this contract since Section 103D-309, Hawaii Revised Statutes, as amended, does not require the State of Hawaii Comptroller's certificate for price-term, open-end, or requirements contracts under which the total amount to be paid CONTRACTOR cannot be accurately estimated at the time the contract is awarded.

All work to be performed and materials to be furnished shall be in accordance with the specifications, the special provisions and plans, if any, the notice to bidders, the instructions to bidders and proposal for «PROJECT\_NO\_ONLY», on file in the office of the Director of Transportation. These documents, together with all alterations, amendments, additions thereto and deductions therefrom, are attached hereto or incorporated herein by reference and made a part of this contract.

The CONTRACTOR hereby covenants and agrees to furnish, perform and/or deliver all labor, supplies, materials, equipment and services as provided herein for a period of

«WORKING\_DAYS» from the date indicated in the notice to proceed from the STATE, with an option to extend for FOUR (4) additional TWELVE (12) MONTH periods, subject to the terms specified in Section «SECTION\_REFERENCING\_OPTION\_YEAR» of the specifications. The total term of this contract shall not exceed SIXTY (60) MONTHS.

All words used herein in the singular number shall extend to and include the plural. All words used in the plural number shall extend to and include the singular. The use of any gender shall extend to and include all genders.

IN WITNESS WHEREOF, the parties hereto have caused this instrument to be duly executed the day and year first above written.

STATE OF HAWAII

\_\_\_\_\_  
Director of Transportation

(Seal)

«CONTRACTOR»

\_\_\_\_\_  
Signature

\_\_\_\_\_  
Print name

\_\_\_\_\_  
Title

\_\_\_\_\_  
Date